

Isofrax® 1260C Modules

Introduction

Isofrax® 1260C Modules combine the performance features of the proven Anchor-Loc® module attachment systems with the revolutionary, new Isofrax Thermal Insulation from Unifrax. Isofrax Thermal Insulation from Unifrax is a revolutionary new fiber that utilizes a unique, patented silica-magnesia chemistry to solve a variety of demanding, high-temperature application problems and also meets European and German regulatory requirements. Isofrax 1260C Blanket, the insulating material in Isofrax 1260C Modules, is the product of a long-term research and development effort by Unifrax to produce an insulating blanket which has the high-temperature performance characteristics required in many applications at temperatures up to 1260°C/2300°F and also meets the regulations described above.

Isofrax 1260C Modules are designed to meet a wide range of application requirements in a variety of heat processing vessels. The Isofrax 1260C Blanket, used to construct the Isofrax 1260C Module, is secured by two alloy support tubes to a metallic module anchor. Flanges on the end of the support tubes effectively lock the position of the tubes relative to the anchor at the time of installation. Isofrax 1260C Modules are manufactured in several configurations. Each type of Isofrax 1260C Module can be easily fastened to interior steel shells of all types of heat processing equipment with one of several different attachment systems. This choice of attachment system is provided to meet a wide range of application needs.

Isofrax 1260C Modules provide many benefits in high-temperature applications, including low thermal conductivity, excellent thermal stability, low heat storage, thermal shock resistance and excellent corrosion resistance. Isofrax 1260C Modules have excellent chemical stability and are unaffected by most chemicals except hydrofluoric and phosphoric acids and concentrated alkalis. If wet by water or steam, thermal and physical properties remain unaffected after drying. Isofrax 1260C Modules also provide superior resistance to attack from molten aluminum alloys at high temperatures.

Product Forms

Isofrax 1260C Blanket is combined with the proven Anchor-Loc attachment systems to provide a complete module system. For more detailed information on material properties for Isofrax 1260C Blanket, please refer to Unifrax Product Information Sheet No. C-1452. Isofrax 1260C Modules are available with Weld-Loc®, Thread-Loc®, and Screw-Loc® attachment systems.



Weld-Loc 1260C Module

A special weld assembly is installed in each module. This assembly permits fusion of the stud base to the furnace casing and allows a threaded fastener to be torqued on the stud, drawing the module to the plate.

Advantages of the Weld-Loc 1260C Module are listed below:

- High installation speed
- Ease and simplicity of installation
- System provides a positive torque test of the welds

Thread-Loc 1260C Module

Provided with an all-thread weld stud and flanged nut, the Thread-Loc 1260C Module is designed for installation on a pre-positioned stud pattern. The Thread-Loc attachment system has several advantages:

- Compatibility with mastic coatings, backup insulation, and foil vapor barriers
- Module design compensates for variations in stud placement
- Access to the welded fastener for full testing before the Module is installed

Screw-Loc 1260C Module

A self-tapping screw supplied with each Screw-Loc Ceramic Fiber Module easily penetrates mild steel up to 12mm in thickness. The Screw-Loc attachment system provides the following installation advantages:

- Multiple, random fastener placement
- Ease of removal and replacement
- Furnace casing preparation is eliminated
- Low-cost installation equipment is readily available

Weld-Loc® 1260C Module

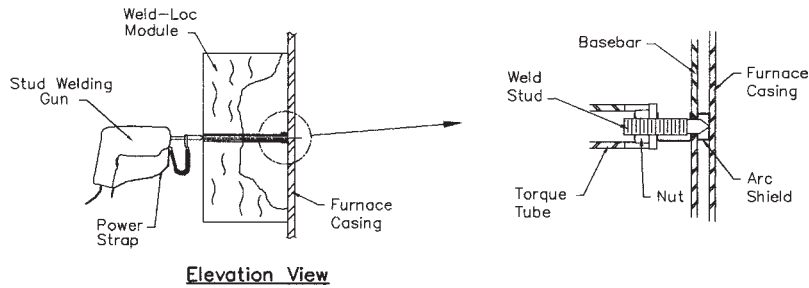

Thread-Loc® 1260C Module

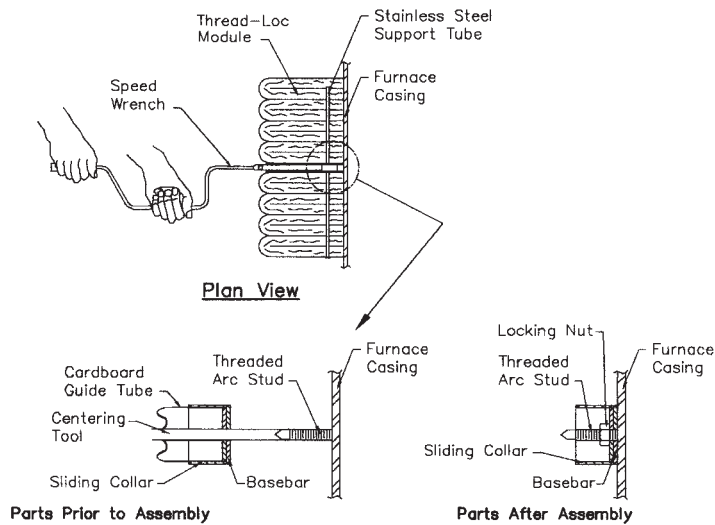

Screw-Loc® 1260C Module

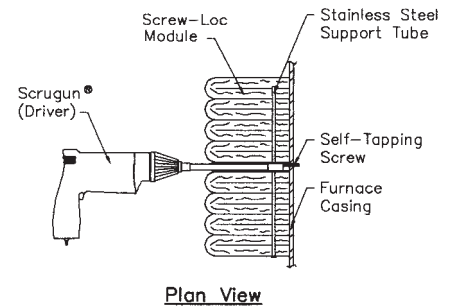

Applications

Isofrax 1260C Modules can be used in many heat processing applications. A partial list is provided below:

- Stress relieving furnaces
- Carbottom heat treating furnaces
- Ladle preheat stands
- Stack, flue and duct linings
- Steel reheating furnaces
- Annealing furnaces
- Process heaters
- Incinerators and boilers
- Ceramic and brick kilns
- Door and cover linings

Isofrax 1260C Modules have a temperature rating of 1260°C, but can withstand short-term temperature excursions above 1260°C with moderate shrinkage. The enhanced thermal stability of Isofrax 1260C Blanket provides a safety margin in the event of a furnace control malfunction or burner failure. This safety margin helps to avoid furnace hot spots and equipment damage resulting from temperature overruns. The following graph compares the margin of safety for Isofrax 1260C Blanket and other high-temperature insulating materials:

Typical Product Properties

Color	Bluish White
Melting Point	>1500°C (2730°F)
Temperature Grade	1260°C (2300°F)
Recommended Operating Temperature ¹	1260°C (2300°F)
Construction	Folded Isofrax 1260C Blanket
Density	160, 192 kg/m ³ (10, 12 pcf)
Module Size (mm)	305 x 305 (12" x 12") 153 x 305 (6" x 12")
Available Thickness	100-305 mm (4"-12")
Specific Gravity	2.54 g/cm ³

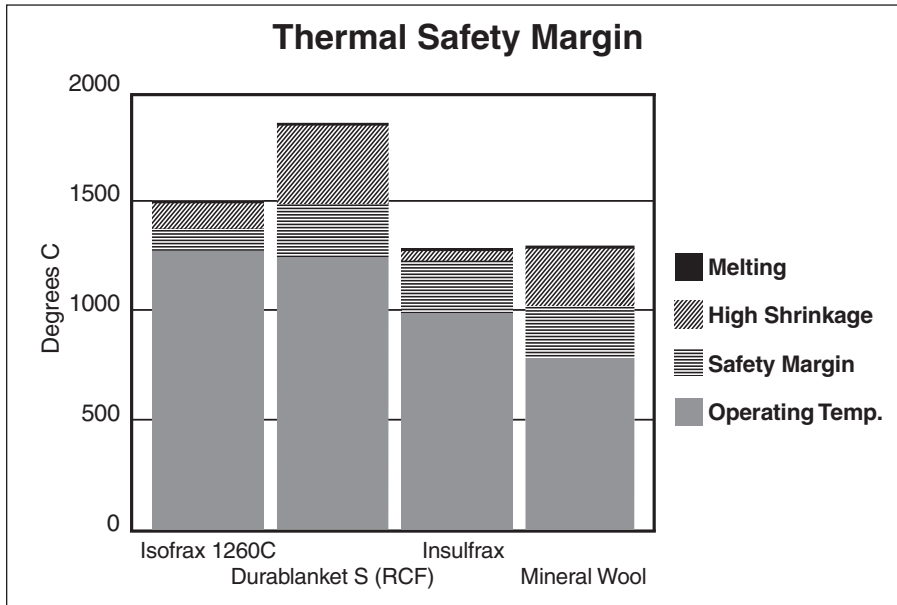

For additional information about product performance or to identify the recommended product for your application, please contact the Unifrax Application Engineering Group at 716-278-3888. Data are average results of tests conducted under standard procedures and are subject to variation. Results should not be used for specification purposes.



Insulating Value

The following table summarizes the insulating characteristics of Isofrax 1260C Modules:

(160 kg/m ³ (10 pcf))	152mm (6") Thickness	203mm (8") Thickness	254mm (10") Thickness	305mm (12") Thickness
Hot Face	Cold Face (°C/°F)	(°C/°F)	(°C/°F)	(°C/°F)
600°C (1112°F)	(66/150)	(57/136)	(52/126)	(49/120)
800°C (1472°F)	(90/195)	(78/172)	(69/157)	(64/147)
1000°C (1832°F)	(124/255)	(105/222)	(93/200)	(85/185)
1200°C (2192°F)	(165/328)	(140/284)	(123/254)	(112/233)
(192 kg/m ³ (12 pcf))				
600°C (1112°F)	(65/148)	(56/134)	(51/125)	(48/118)
800°C (1472°F)	(88/190)	(76/168)	(68/154)	(62/144)
1000°C (1832°F)	(118/245)	(101/214)	(89/193)	(81/178)
1200°C (2192°F)	(155/312)	(132/270)	(117/242)	(105/222)

All heat flow calculations are based on a surface emissivity factor of 0.90, an ambient temperature of 27°C (80°F) and 0 km/h (mph) wind velocity, unless otherwise stated.

Health and Safety Information

Isofrax Thermal Insulation from Unifrax, according to Directive 97/69/EC, possesses a fiber chemistry within the regulatory definition of a "man-made vitreous (silicate) fiber with random orientation with alkaline oxide and alkaline earth oxide content greater than 18% by weight." Isofrax fibers have been tested pursuant to EU protocol ECB/TM/26, Revision 7, Nota Q, Directive 97/69/EC, with results that are below regulatory thresholds. As a result, Isofrax Thermal Insulation does not require additional labeling, further testing or special handling practices. In addition, Intratracheal Instillation Biopersistence Testing per the German Hazardous Substance Ordinance has been conducted on Isofrax fibers with results that are below German regulatory thresholds. Refer to the product Material Safety Data Sheet (MSDS) for recommended work practices and other product safety information.

Notes:

- (1) The recommended operating temperature of Isofrax 1260C Modules is determined by irreversible linear change criteria, not melting point.



Unifrax I LLC

Corporate Headquarters
2351 Whirlpool Street
Niagara Falls, New York 14305-2413
Telephone: 716-278-3800
Telefax: 716-278-3900
Internet: www.unifrax.com
Email: info@unifrax.com