

Insulfrax® 1100C Modules

Introduction

Insulfrax® 1100C Modules are a family of high-temperature module products based on Unifrax's Anchor-Loc® attachment systems. Modules used in the Anchor-Loc® systems are constructed with Insulfrax S Blanket. Each type of Insulfrax 1100C Module can be easily fastened to interior steel shells of all types of heat processing equipment with several different attachment systems.

Insulfrax S Blanket, which is utilized in Insulfrax 1100C Modules, is based on a calcium, magnesium, silicate chemistry to provide thermal insulation at recommended operating temperatures up to 2012°F (1100°C); Insulfrax products also meet European regulatory requirements (Directive 97/69/EC).

Insulfrax 1100C Modules are fabricated from eight folds of one-inch thick Insulfrax S Blanket to achieve precompression of the block during manufacture. The folded blanket layers are secured to the metallic module anchor by two alloy tubes. Flanges on the end of the tubes effectively lock the position of the tubes relative to the anchor at the time of installation.

A partial list of applications for Insulfrax 1100C modules is provided below:

- Annealing furnace linings
- Slow cool covers for slabs and ingots
- Process heater linings
- Aluminum homogenizing furnace linings
- Aluminum ladle covers
- Personnel heat shields
- Heat treating furnace linings
- Flue stack and duct linings
- Field steam generator linings

Note that Insulfrax 1100C modules exhibit excellent thermal stability after exposure to moisture or high humidity.

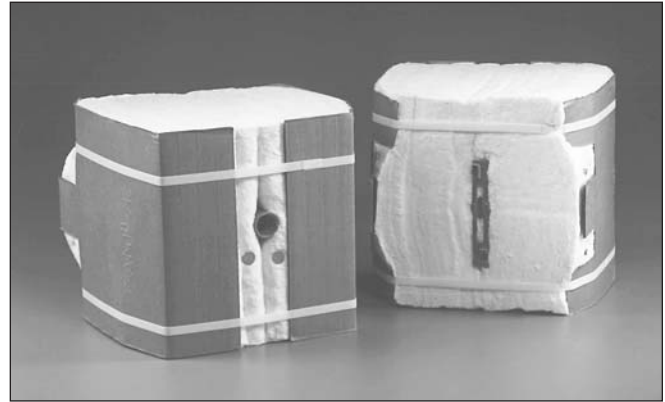

Product Forms

Insulfrax 1100C Modules are manufactured in several configurations. A choice of attachment systems is provided to meet a wide range of applications.

Weld-Loc® 1100C Modules

A special weld assembly is installed in each Weld-Loc 1100C module. This stud assembly permits fusion of the stud base to the furnace casing and allows a threaded fastener to be torqued on the stud, drawing the module to the plate. Advantages offered by the Weld-Loc module include:

- High installation speed
- Ease and simplicity of installation
- Permits random placement of modules on the casing
- Multiple welds per module are possible
- System provides a positive torque test of the welds

Power-Loc® 1100C Modules

A hardened steel pin mechanically secures each Power-Loc 1100C module to the steel casing plate. The anchor pin is installed with a special Hilti® powder actuated fastening tool and powder booster. Advantages which are offered by the Power-Loc 1100C module include:

- High installation speed
- Casing preparation is eliminated
- Permits random placement of modules on the casing
- Ease and simplicity of installation
- Positive mechanical/attachment of modules to the casing plate
- Setup time is reduced

Hilti® is a trademark of Hilti Tool Corporation.

Refer to the product Material Safety Data Sheet (MSDS) for recommended work practices and other product safety information.

Thread Loc® 1100C Modules

Provided with an all-thread weld stud and flanged nut, the Thread Loc 1100C module is designed for installation on a pre-positioned stud pattern. The Thread Loc attachment system has several advantages:

- Compatibility with mastic coatings, back-up insulation, and foil vapor barriers
- Module design compensates for variations in stud placement
- Access to the welded fastener for full testing before the module is installed

Screw Loc® 1100C Module

A self-tapping screw supplied with each Screw Loc 1100C module easily penetrates mild steel up to 1/2" in thickness. The Screw Loc attachment system provides the following installation advantages:

- Multiple, random anchor placement
- Ease of removal and replacement
- Furnace casing preparation is eliminated
- Low cost installation equipment is readily available

Available Insulfrax 1100C Modules

305 mm x 610 mm (12" x 24"), 305 mm x 305 mm (12" x 12"), 305 mm x 152.5 mm (12" x 6")

Module Type	Temperature Grade ¹	Recommended Operating Temperature Limit ²	Construction	Module Density
Insulfrax 1100C	1260°C (2300°F)	1100°C (2012°F)	Folded Insulfrax S Blanket	128 kg/m ³ (8 lb/ft ³) 160 kg/m ³ (10 lb/ft ³)

¹ Temperature Grade based on European Norm (EN 1094).

² The recommended operating temperature of Insulfrax products is determined by irreversible linear change criteria, not melting point.

Available Attachment Option

A. Weld-Loc® 1100C Module

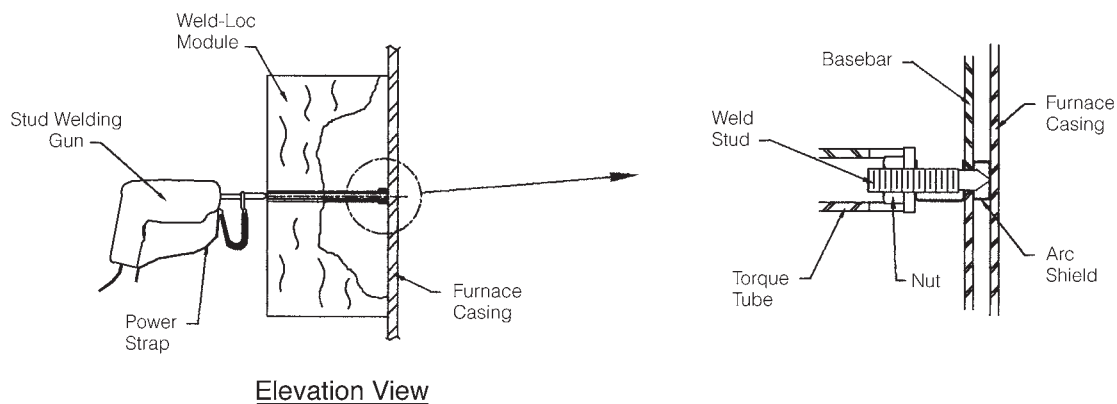

B. Power-Loc® 1100C Module

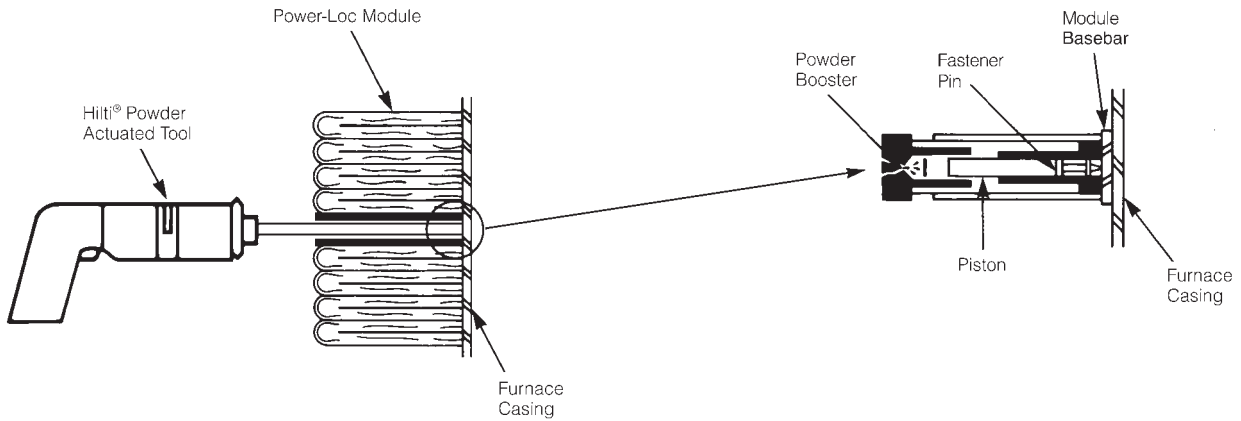

C. Thread Loc® 1100C Module

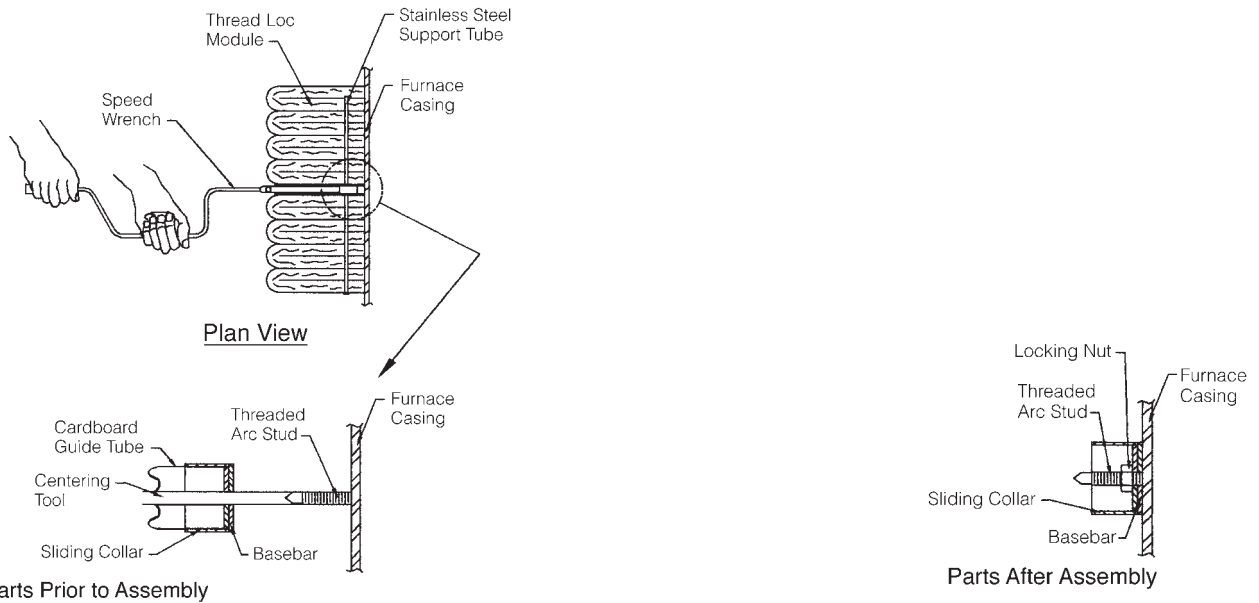

D. Screw Loc® 1100C Module

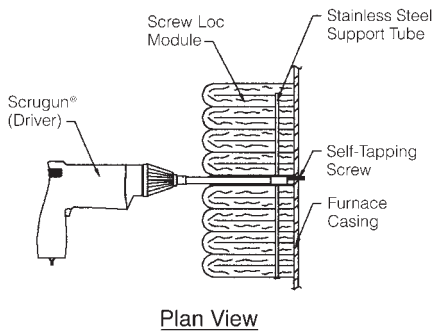

Insulfrax 1100C Modules

Insulfrax 1100C Modules – 128 kg/m³ (8 lbs/ft³)

Hot Face °C (°F)	Insulation Thickness – mm (in)	Cold Face Temperature °C (°F)			
		102 (4)	152 (6)	203 (8)	254 (10)
600 (1112)		78 (172)	65 (147)	56 (133)	51 (125)
800 (1472)		109 (228)	87 (190)	75 (168)	67 (154)
1000 (1832)		148 (300)	118 (246)	101 (214)	89 (194)

Insulfrax 1100C Modules – 160 kg/m³ (10 lbs/ft³)

Hot Face °C (°F)	Insulation Thickness – mm (in)	Cold Face Temperature °C (°F)			
		102 (4)	152 (6)	203 (8)	254 (10)
600 (1112)		76 (170)	63 (145)	55 (132)	50 (123)
800 (1472)		105 (221)	84 (184)	73 (164)	65 (150)
1000 (1832)		141 (287)	112 (236)	96 (206)	85 (186)

All heat flow calculations are based on a surface emissivity factor of .90, an ambient temperature of 27°C (80°F) and zero wind velocity, unless otherwise stated. All thermal conductivity values for Insulfrax materials have been measured in accordance with ASTM Test Procedure C-177. When comparing similar data, it is advisable to check the validity of all thermal conductivity values and ensure the resulting heat flow calculations are based on the same condition factors. Variations in any of these factors will result in significant differences in the calculated data.

Bonded 1100C Modules

Bonded 1100C modules provide the benefits of Insulfrax fiber in new construction or the upgrade of existing refractory for a wide range of heat processing equipment. The Bonded 1100C modules can be installed as a hot face veneer over existing refractory, or with Unifrax's Hefty Lock™ hardware as a full thickness lining.

Manufacture of Bonded 1100C modules is based on Insulfrax S Blanket, a high-strength spun fiber blanket. This blanket is folded, then tightly compressed and banded to form the Bonded 1100C block. These bonded modules are offered in two standard densities and a range of thicknesses to provide peak performance in applications operating up to 1100°C (2012°F).



Bonded 1100C Module Installation Over Refractory

Bonded 1100C modules are typically mortared into place over hard refractory using .908 kg to 1.36 kg (2 to 3 pounds) of Fiberstick™ mortar per module. This lining over refractory installation technique (veneer) with Bonded 1100C modules offers the benefits of Insulfrax fiber in addition to the performance advantages listed below:

- Reduced heat loss
- Faster furnace cycling
- Increased resistance to thermal shock
- Improved sound absorption
- Low installed cost
- Reduced heat storage
- Reduced fuel costs

Typical applications for Bonded 1100C modules include heat treating furnaces, aluminum processing furnaces and process heaters operating under 1100°C (2012°F).

For additional information about the installation of bonded module veneers, refer to the Fiberwall™ Installation Manual (Form C-729).



Bonded 1100C Module Installation With the Hefty Lock System

Unifrax's Hefty Lock alloy steel hardware is combined with Bonded 1100C modules for full thickness lining installations at temperatures up to 1100°C (2012°F).

The Hefty Lock hardware system consists of an alloy base bar which is fastened to the casing and an alloy tine which passes through the Bonded 1100C module and locks it to the base bar.

The Hefty Lock module/Bonded 1100C system combines the performance benefits of Bonded 1100C modules with the design and installation advantages listed below:

- Field fabrication of special block shapes is simplified.
- Backup lining, furnace casing coatings and backup layered linings are compatible with the Hefty Lock Bonded 1100C system.
- Prepositioning of Hefty Lock base bars insures tight module compression, eliminating casing hot spots.

Complete details of Hefty Lock module installation procedures are available in the Fiberwall Installation Manual, Form C-729.

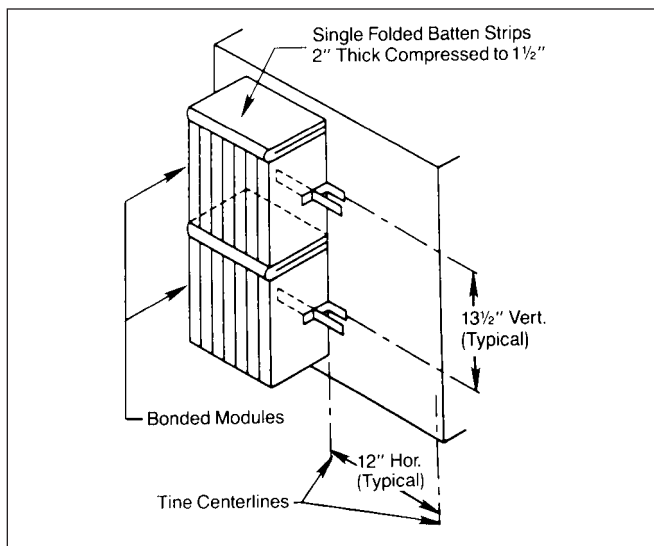

The Hefty Lock/Bonded 1100C module system is used in a wide range of applications in the temperature range up to 1100°C (2012°F). Typical applications include:

- Annealing furnaces
- Aluminum homogenizing furnaces and soaking pits
- Process heaters
- Stacks, ducts and flue linings
- Heat treating furnace linings
- Fume incinerators
- Field steam generators

Health and Safety Information

Insulfrax Thermal Insulation from Unifrax, according to Directive 97/69/EC, possesses a fiber chemistry within the regulatory definition of a "man-made vitreous (silicate) fiber with random orientation with alkaline oxide and alkaline earth oxide content greater than 18% by weight." Insulfrax fibers have been tested pursuant to EU protocol ECB/TM/26, Revision 7, Nota Q, Directive 97/69/EC, with results that are below regulatory thresholds. As a result, Insulfrax Thermal Insulation does not require additional labeling or further testing. Refer to the product Material Safety Data Sheet (MSDS) for recommended work practices and other product safety information.

Heat Flow Analysis

Bonded 1100C Modules Module Over Refractory Veneer

Bonded 1100C/Fireclay Brick		Folded Modules 112 kg/m ³ (7 lb/ft ³)			
		Cold Face Temperature °C (°F)			
Hot Face °C (°F)	Insulation Thickness – mm (in) Refractory Thickness – mm (in)	0 (0) 228 (9)	51 (2) 228 (9)	76 (3) 228 (9)	102 (4) 228 (9)
600 (1112)		140 (287)	87 (191)	76 (170)	68 (156)
800 (1472)		184 (366)	123 (257)	108 (228)	96 (206)
1000 (1832)		227 (445)	165 (333)	146 (298)	131 (270)

Bonded 1100C/Fireclay Brick		Folded Modules 149 kg/m ³ (9.3 lb/ft ³)			
		Cold Face Temperature °C (°F)			
Hot Face °C (°F)	Insulation Thickness – mm (in) Refractory Thickness – mm (in)	0 (0) 228 (9)	51 (2) 228 (9)	76 (3) 228 (9)	102 (4) 228 (9)
600 (1112)		140 (287)	86 (188)	74 (167)	66 (153)
800 (1472)		184 (366)	119 (249)	103 (219)	92 (199)
1000 (1832)		227 (445)	158 (320)	138 (283)	123 (256)

Bonded 1100C/Hefty Lock™ Full Thickness Lining

Fiberwall Bonded 1100C		Folded Modules 112 kg/m ³ (7 lb/ft ³)			
		Cold Face Temperature °C (°F)			
Hot Face °C (°F)	Insulation Thickness – mm (in)	102 (4)	152 (6)	203 (8)	254 (10)
600 (1112)		79 (175)	65 (150)	57 (136)	52 (126)
800 (1472)		112 (235)	90 (195)	77 (172)	69 (157)
1000 (1832)		155 (312)	124 (256)	106 (223)	93 (201)

Fiberwall Bonded 1100C		Folded Modules 149 kg/m ³ (9.3 lb/ft ³)			
		Cold Face Temperature °C (°F)			
Hot Face °C (°F)	Insulation Thickness – mm (in)	102 (4)	152 (6)	203 (8)	254 (10)
600 (1112)		77 (171)	63 (147)	56 (133)	51 (124)
800 (1472)		106 (225)	82 (187)	74 (166)	66 (152)
1000 (1832)		145 (294)	116 (241)	98 (210)	87 (190)

All heat flow calculations are based on a surface emissivity factor of .90, an ambient temperature of 27°C (80°F) and zero wind velocity, unless otherwise stated. All thermal conductivity values for Unifrax materials have been measured in accordance with ASTM Test Procedure C-177. When comparing similar data, it is advisable to check the validity of all thermal conductivity values and ensure the resulting heat flow calculations are based on the same condition factors. Variations in any of these factors will result in significant differences in the calculated data.

For additional information about product performance or to identify the recommended product for your application, please contact the Unifrax Application Engineering Group at 716-278-3888.

