

Design Number UNI/BI 120-03
FIRE RESISTANT GREASE DUCT
 Unifrax I LLC
 FyreWrap® Elite™ 1.5 Duct Insulation
CAN/ULC S144
Fire Resistance Rating – 2 hours
 Fire Inside Duct – Meets Requirements
 Fire Outside Duct (Fire Engulfment):
 Stability – 2 hours
 Integrity – 2 hours
 Insulation – 2 hours

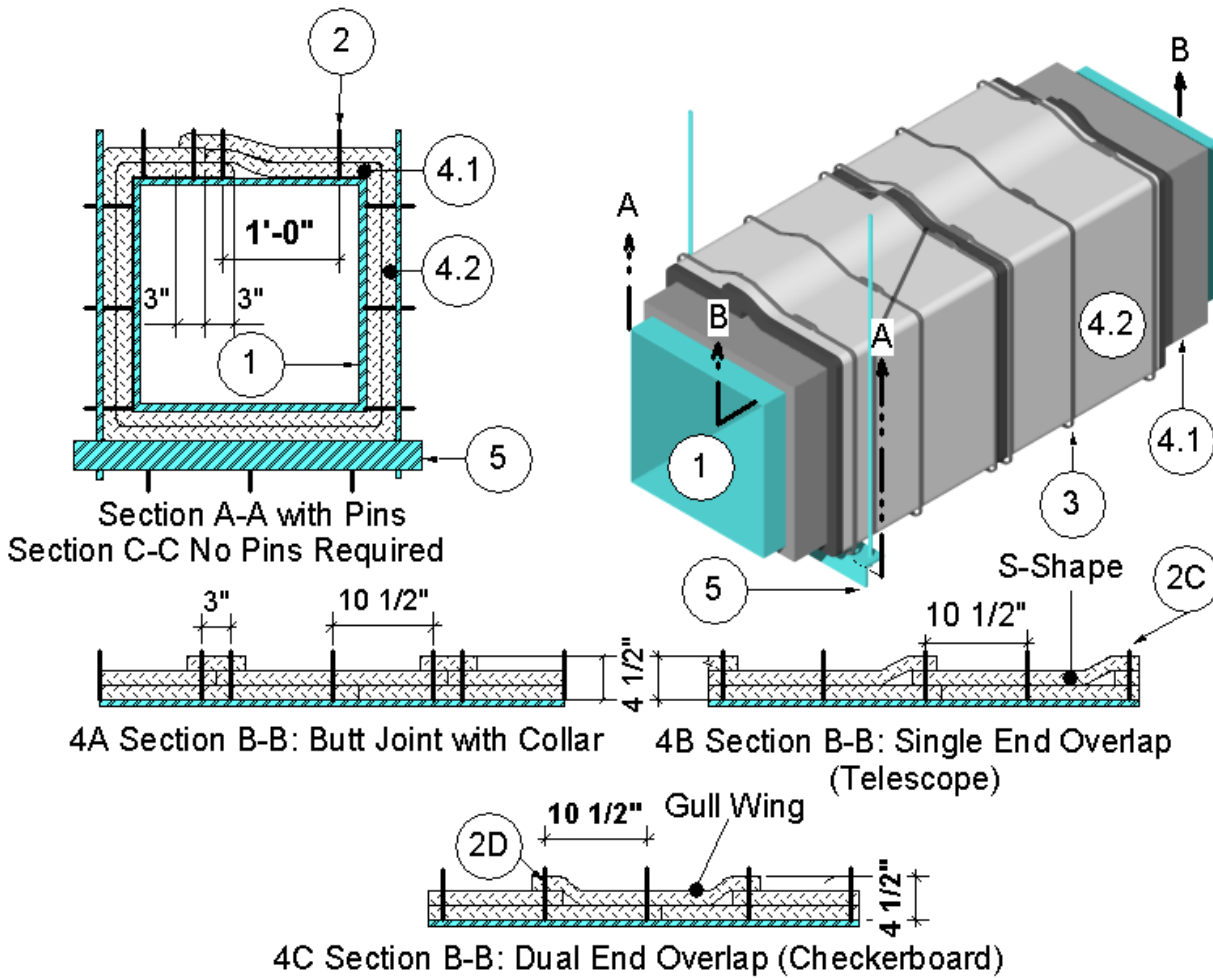

Figure 1

1. GREASE DUCT: Use a continuously-welded, liquid-tight, rectangular duct system with horizontal and vertical shafts constructed of 16 GA sheet steel with a

maximum 2,401 in² (15,490 cm²) area, maximum 49 in. (1245 mm) dimension, and a maximum 4:1 width-to-height ratio.

When required, equip the duct with an access door (Item 6).

- A. Reinforce the grease duct to NFPA 96 requirements designed to carry the weight of the grease duct assembly covered with two layers of duct insulation (Item 4) under a fire load equivalent to that of the ISO 6944 exposure and the ISO 834 time-temperature curve.
 - B. Rigidly support the grease duct as specified in Item 5 or in accordance with NFPA 96 requirements when not specified herein or when those requirements are greater.
2. PINS: Refer to Figure 1. Use minimum 12 GA, 6-1/2 in. (165 mm) long, steel insulation pins or minimum 12 GA, steel cup head insulation pins. The length of the cup head pins may be increased if needed where the thickness of insulation is greater due to overlapping installation techniques. Weld pins to the grease duct (Item 1), if using cup head insulation pins, do so after application of duct insulation (Item 4). Match the following fastener method with corresponding duct insulation (Item 4) installation method.
- A. Butt Joint with Collar: Refer to Figure 1, 4A Section B-B. Locate pins at all blanket overlaps, on all sides of the grease duct (Item 1), and meet the following requirements.
 - i. Space pins maximum 12 in. (305 mm) apart in rows around the perimeter of grease duct (Item 1). Locate pins maximum 6-3/4 in (171 mm) from the edges of the grease duct (Item 1). Refer to Figure 1, Section A-A.
 - ii. Space two rows of pins 3 in. (76 mm) apart centered directly over each transverse joint and collar, and space rows a maximum of 10-1/2 in. (267 mm) apart elsewhere along the length of the grease duct (Item 1), Refer to Figure 1, 4A Section B-B.
 - iii. After the duct insulation (Item 4) is installed, place minimum 2-1/2 in. x 2-1/2 in. (64 mm X 64 mm) square, galvanized steel, self-locking washer clips onto each duct insulation pin.
 - iv. After all the clips are installed, cut off or bend flush with duct insulation (Item 4) the pins that are too long.
- B. Single End Overlap (Telescope): Refer to Figure 1, 4B Section B-B. Locate pins at all blanket overlaps, on all sides of the grease duct (Item 1), and meet the following requirements.
- i. Space pins maximum 12 in. (305 mm) apart in rows around the perimeter of grease duct (Item 1). Locate pins maximum 6-3/4 in. (171 mm) from the edges of the grease duct (Item 1). Refer to Figure 1, Section A-A.
 - ii. Space the rows of pins maximum 10-1/2 in. (267 mm) apart along the length of the grease duct (Item 1). Refer to Figure 1, 4B Section B-B.
 - iii. After the duct insulation (Item 4) is installed, place minimum 2-1/2 in. x 2-1/2 in. (64 mm X 64 mm) square, galvanized steel, self-locking washer clips onto all duct insulation pins.
 - iv. After all the clips are installed, cut off or bend flush with duct insulation (Item 4) the pins that are too long.
- C. Dual End Overlap (Checkerboard): Refer to Figure 1, 4C Section B-B. Locate pins at all blanket overlaps, on all sides of the grease duct (Item 1), and meet the following requirements.

- i. Space pins maximum 12 in. (305 mm) apart in rows around the perimeter of grease duct (Item 1). Locate pins maximum 6-3/4 in. (171 mm) from the edges of the grease duct (Item 1). Refer to Figure 1, Section A-A.
 - ii. Space the rows of pins maximum 10-1/2 in. (267 mm) apart along the length grease duct (Item 1). Refer to Figure 1, 4C Section B-B.
 - iii. After the duct insulation (Item 4) is installed, place minimum 2-1/2 in. x 2-1/2 in. (64 mm X 64 mm) square, galvanized steel, self-locking washer clips onto all duct insulation pins.
 - iv. After all the clips are installed, cut off or bend flush with duct insulation (Item 4) pins that are too long.
3. **BANDING (optional):** Use minimum 1/2 in. (13 mm) wide, 0.015 in. (0.4 mm) thick stainless steel bands or minimum 1/2 in. (13 mm) wide, 0.015 in. (0.4 mm) thick carbon steel bands secured with minimum 1 in. (25 mm) long stainless or carbon steel crimp clamps, each to be used with their respective banding type. When needed to ease installation, use filament tape as a temporary hold for the duct insulation (Item 4) prior to banding. Tension the banding to hold the duct insulation (Item 4) in place without cutting or damaging the duct insulation (Item 4) or grease duct (Item 1).
- A. **Banding and Pin Method:** When using banding and pin (Item 2) combination, position and weld pins to the grease duct (Item 1) on bottom of grease duct for horizontal sections and on one of the wide sides for vertical sections. Space pins a maximum of 12 in. (305 mm) on center transversely and also centered at the overlaps of the duct insulation (Item 4) as indicated by the installation method chosen. Space pins maximum 10-1/2 in. (267 mm) apart to create rows of pins along the length of the grease duct. Locate pins maximum 12 in. (305 mm) from the edges of the grease duct. No other pins are required. Overlap all duct insulation joints a minimum of 3 in. (76 mm) Secure the duct insulation to the pins with 2-1/2 in. (64 mm) square or round galvanized steel speed clips. Turn down or cut off pins that extend beyond the duct insulation. After duct insulation is installed, apply banding. Locate bands 1-1/2 in. (38 mm) from each edge of the outer layer duct insulation (Item 4), centered on the overlap. For the butt joint with collar insulation method (refer to Item 4A and Figure 1, 4A Section B-B) ensure that a band is placed over the collar on each side of the joint such that the bands replace the two sets of pins (Item 2) required when using the pin (Item 2) method.
- B. **Banding Only Method:** Use banding only method as an alternative duct insulation (Item 2) fastening method, only when the grease duct (Item 1) width and height are both less than or equal to 24 in. (610 mm). After second layer of duct insulation (Item 4) is installed, apply banding. Locate bands 1-1/2 in. (38 mm) from each edge of the duct insulation (Item 4), centered on the overlap. For the butt joint with collar insulation method (refer to Item 4A and Figure 1, 4A Section B-B) ensure that a band is placed over the collar on each side of the joint such that the bands replace the two sets of pins (Item 2) required when using the pin (Item 2) method. For the compressed butt joint insulation method (Item 4D), ensure that banding is located nominal 2-1/2 in. (64 mm) on center from each side of the compressed joint. For insulation methods with overlapping joints (Items 4A to 4C) place additional banding in the field area between the overlaps spaced a maximum of 10-1/2 in. (267 mm) on center. For the

compressed butt joint insulation method (Item 4D) place additional banding in the field area between the compressed joints spaced a maximum of 9 in. (229 mm) on center. Refer to Figure 1, Section C-C. No pins (Item 2) are required when this banding option is used.

4. **CERTIFIED COMPANY:** Unifrax I LLC

CERTIFIED PRODUCT: Duct Insulation

MODEL: FyreWrap® Elite™ 1.5

DUCT INSULATION: Apply two layers of the nominal 1-1/2 in. (38 mm) thick, 6 pcf density (96 kg/m³) duct insulation over the entire surface of the grease duct (Item 1). Apply the first layer of duct insulation with longitudinal joints overlapping a minimum of 3 in. (76 mm) and transverse joints butted with the following exception: when Banding and Pin Method (Item 3A) is used for grease ducts having a cross-sectional dimension greater than 24 in. (610 mm) install transverse joints with a minimum overlap of 3 in. (76 mm). Offset the second outer layer (Figure 1, 4.2) one half the width of the inner first layer (Figure 1, 4.1) so that the joints of the inner first layer (Figure 1, 4.1) are covered by and approximately in the center of the second outer layer (Figure 1, 4.2). Apply the second layer (Figure 1, 4.2) using one of the methods (A, B or C) described below. Use blanket, available in various widths, that is fully encapsulated with a polypropylene-foil scrim. Wrap one layer of insulation around the grease duct (Item 1) perimeter so that each terminating end of duct insulation overlaps onto the starting end of duct insulation a minimum of 3 in. (76 mm) at all longitudinal joints. Stagger the longitudinal overlap location so that no two consecutive adjacent overlaps align. Refer to Figure 1, 4A Section A-A for transverse overlap section view. Cover all visually-exposed ends and edges of duct insulation with nominal 4 in.

(102 mm) wide, pressure-sensitive, aluminum foil tape.

- A. **Butt Joint with Collar:** Refer to Figure 1, 4A Section B-B. Wrap the grease duct (Item 1) with two layers of duct insulation installed with butt joints at all circumferential joints. Apply the first layer, center pieces of duct insulation over 3 in. (76 mm) wide pin bay. Butt each end of each piece of duct insulation together with preceding edge of duct insulation. Each piece of installed duct insulation width is its nominal width. (Example: each piece of nominal 24 in. (610 mm) wide duct insulation when installed is 24 in. (610 mm) wide.) Offset the second layer of duct insulation so that the butt joint of the first layer of duct insulation is centered under the second layer of duct insulation and install in same manner as first layer of duct insulation. Place and center 6 in. (152 mm) wide collar of duct insulation over the butt joint. Overlap 6 in. (152 mm) wide collar onto each adjacent duct insulation 3 in. (76 mm). Verify all duct insulation butt joints with collars are three layers of duct insulation in overall thickness.
- B. **Single End Overlap (Telescope):** Refer to Figure 1, 4B Section B-B. Wrap the grease duct (Item 1) with two layers of duct insulation. Install first layer of duct insulation with transverse joints butted and longitudinal joints overlapping a minimum of 3 in. (76 mm). Install second layer using the following installation technique:
- i. Starting at one end of the grease duct (Item 1), apply the first piece of duct insulation around the grease duct (Item 1) overlapping on itself by minimum 3 in. (76 mm) which must be located at the pins (Item 2). Refer Figure 1, Section A-A.

- ii. Position and overlap the leading edge of the second piece of duct insulation nominally 3 in. (76 mm) over the flush edge of the first piece of duct insulation. Place the opposite edge of the second piece of duct insulation flush against the surface of the first layer of duct insulation. An “S-shaped” cross section of the duct insulation is created. Refer to Figure 1, 4B Section B-B.
 - iii. Apply all additional pieces of duct insulation as “S-shaped” cross section of the duct insulation in compliance with Item 4Bii.
- C. Dual End Overlap (Checkerboard): Refer to Figure 1, 4C Section B-B. Apply the first layer of duct insulation with transverse joints butted and longitudinal joints overlapping a minimum of 3 in. (76 mm). Install second layer using the following installation technique: After installation, verify all duct insulation overlaps are three layers of duct insulation in overall thickness.
- i. Wrap the first piece of duct insulation around the grease duct (Item 1) so that the duct insulation is flush against the surface of the first layer of duct insulation. Position the starting and terminating end of the duct insulation to overlap pins (Item 2) a minimum of 1-1/2 in. (38 mm) while the edges of the duct insulation overlaps the rows of pins (Item 2) a minimum of 3 in. (76 mm).
 - ii. Position the second piece of duct insulation to ensure minimum 3 in. (76 mm) overlap on adjacent pieces of duct insulation. Install the second piece in the same manner as the first.
 - iii. Cover the first layer of duct insulation that is exposed between the edges of the first two pieces of duct insulation with another piece of duct insulation. Position the starting end of the duct insulation to overlap pins (Item 2) a minimum of 1-1/2 in. (38 mm) while the edges of the duct insulation overlap the adjacent edges of the two pieces of installed duct insulation a minimum of 3 in. (76 mm).
 - iv. Position the second layer of duct insulation so that the first layer butt joint is centered under the second layer of duct insulation and ensure three inch overlaps in transverse and longitudinal directions.
- D. Compressed Butt Joint (Not Shown): Use this method only for grease ducts (Item 1) with maximum dimensions of 24 in. x 24 in. (610 mm x 610 mm). Apply the first layer of duct insulation (Item 4) with 1 in. (25 mm) compression butt joints in the transverse direction and longitudinal joints overlapping a minimum of 3 in. (76 mm). Secure first layer of duct insulation (Item 4) using 1 in. (25 mm) wide filament tape. Center the second layer duct insulation (Item 4) pieces over the first layer butt joints and install with 1 in. (25 mm) compression butt joints in the transverse direction and longitudinal joints overlapping a minimum of 3 in. (76 mm). After installing the second layer of duct insulation (Item 4), secure the duct insulation (Item 4) with banding (Item 3) located on both sides of the transverse butt joints nominal 2-1/2 in. (64 mm) on center from the joint and maximum 9 in. (229 mm) in the field between the joints. Seal compression butt joints and exposed duct insulation (Item 4)

edges on the second layer of duct insulation (Item 4) with nominal 3 in. (76 mm) wide aluminum foil tape.

5. SUPPORTS: Support the horizontal portion of the insulated grease duct (Item 1) using an un-insulated “trapeze” system composed of a steel angle as the trapeze cross-member and two (2), threaded, steel rods connected using nuts and washers. Connect the threaded steel rods to the bottom of the floor assembly using an attachment method designed to carry the weight of the greaseduct (Item 1) with duct insulation (Item 4) under a fire load equivalent to that of the ISO 6944 exposure and the ISO 834 time-temperature curve for the rated period. Place one (1) threaded steel rod at each end of the trapeze cross-member. Center grease duct (Item 1) with duct insulation (Item 4) on trapeze cross-member. Space threaded steel rods a minimum of 1 in. (25 mm) and maximum 6 in. (152 mm) from surface of the insulated grease duct. Extend trapeze cross-member at least 2 in. (51 mm) past each threaded, steel rod. Use minimum 2 in. x 2 in. x 1/4 in. (51 mm x 51 mm x 6 mm) steel angle with minimum 1/2 in. (13 mm) diameter threaded, steel rods with trapeze supports spaced a maximum 60 in. (1524 mm) on center. Where grease duct (Item 1) penetrates a fire rated floor ceiling assembly (Item 7D), support, prior to installing duct insulation (Item 4), using un-insulated 1-1/2 in. x 1-1/2 in. x 1/4 in. (38 mm x 38 mm x 6 mm) steel angles welded to the grease duct (Item 1) and a supporting steel frame designed and constructed to meet the requirements of NFPA 96.

6. ACCESS DOOR: When required by NFPA 96, install an access door using one of the options described below:

A. LISTED COMPANY: Ductmate Industries Incorporated

LISTED PRODUCT: Pre-Fabricated Access Door

MODELS:

- Ductmate™ Ultimate™
(Maximum Size Allowed 24 in. x 18 in. (610 mm x 457 mm)) when insulation installed using a pin only installation (Item 2) method. When installed in a grease duct wrapped using banding only method (Item 3) for the insulation installation, maximum size allowed is 12 in. x 8 in. (305 mm x 203 mm) or 10 in. x 10 in. (254 mm x 254 mm).
- Ductmate™ FD 2000 (F2-HT)
(Maximum Size Allowed 12 in. x 8 in. (305 mm x 203 mm))

LISTED COMPANY: CL Ward, Inc.

LISTED PRODUCT: Pre-Fabricated Access Door

MODELS:

- High Temp #HT2000
(Maximum Size Allowed 12 in. x 8 in.)

LISTED COMPANY: Price Manufacturing Corp

LISTED PRODUCT: Pre-Fabricated Access Door

MODELS:

- FD2000 Fire Door
(Maximum Size Allowed w/o Field Modifications 12 in. x 8 in.)
*(Maximum Size Allowed w/ Field Modifications 24 in. x 18 in.)

OPTIONAL PRE-FABRICATED ACCESS DOORS: Refer to Figure 2. Mark a clean-out access opening location on the insulated grease duct (Item 1) at its mid-height along the horizontal section. Cut an opening in the duct insulation (Item 4) the same size as the outside dimension of the desired pre-fabricated access door model. Remove and discard the cut duct insulation (Item 4). Cut an opening into the side of the grease duct (Item 1) according to the manufacturer's instructions for the size of the pre-fabricated access door to be installed. Install and tightly secure the pre-fabricated access door in accordance with the manufacturer's instructions to the grease duct (Item 1). Cut the outer layer of duct insulation (Item 4) so that a 1 in. (25 mm) perimeter of the inner layer of duct insulation (Item 4) is seen, creating a "stair-step."

*For Price doors larger than 12 in. x 8 in., modifications need to be made in the field. For sizes up to and including 18 in. x 14 in., four 3/8 in. threaded steel rods (one in each corner of the access door) will need to be added to secure the access door and the cover plate. They should be located 2 in. from the edges of the access door. For sizes larger than 18 in. x 14 in. up to the maximum size of 24 in. x 18 in., two bolts will need to be added 8-1/2 in. apart. These shall be centrally located on the door, on either side of the handle, and aligned with the longer dimension of the door. All additional bolts are to be welded to the inner plate of the access door and secured to the cover plate with wing nuts. Drill holes in the outer plate of the access door and the cover plate to match bolt locations.

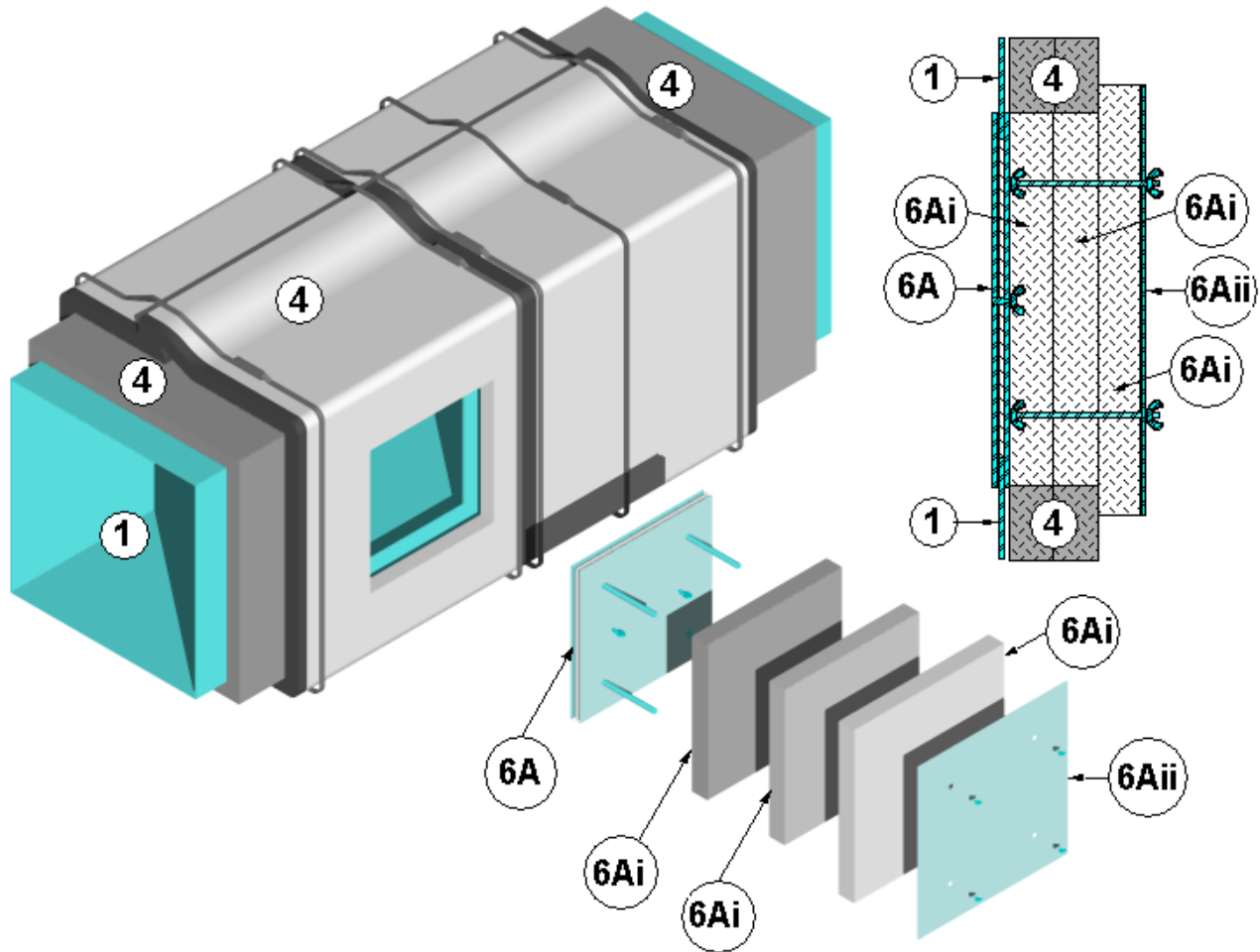

Figure 2 – Ductmate Pre-fabricated Access Door

- i. CERTIFIED COMPANY:
Unifrax I LLC

CERTIFIED PRODUCT:
Duct Insulation

MODEL: FyreWrap® Elite™ 1.5

ACCESS INSULATION: Refer to Figure 2. Remove the four (4), 3/8 in. (10 mm) diameter, corner-thumb bolts and replace them with four (4), 3/8 in. (10 mm) diameter, all-thread, steel rods extending from pre-fabricated access door (Item 6A).

Apply three (3) layers of access insulation over the pre-fabricated access door (Item 6A) as follows. Cut the first piece of rectangular access insulation a minimum 1 in. (25 mm) larger on all sides than the clean-out access opening. Position, square, and impale the first piece of the access insulation over the four (4), 3/8 in. (10 mm) diameter, all-thread, steel rods extending from pre-fabricated access door (Item 6A). Press the first piece of access

insulation flush over the pre-fabricated access door (Item 6A). Compress and abut the cut edges of the first piece of the access insulation against the cut edges of opening in the duct insulation (Item 4). Cut a second piece of access insulation 1 in. (25 mm) larger on all sides than the first piece of access insulation. Press the second piece of access insulation flush over the first piece of access insulation. Compress and abut the cut edges of the second piece of the access insulation against the cut edges of opening in the duct insulation (Item 4). Cut a third piece of rectangular access insulation a minimum of 2 in. larger than the second piece of access insulation on all sides, creating a “stair-step.” Seal cut edges of the third piece of access insulation with nominal 4 in. (102 mm) wide aluminum foil tape. Position, square, and impale the third piece of the access insulation over the four (4), 3/8 in. (10 mm) diameter, all-thread, steel rods extending from pre-fabricated access door (Item 6A). Press the third piece of access insulation flush over second piece of access insulation. Secure access insulation to the insulation pins with 1-1/2 in.

(38 mm) square or round, galvanized or stainless steel, speed clips. Turn down or cut off insulation pins that extend beyond the second piece of access insulation. Optional step, place maximum 4 in. (102 mm) long, steel tubing over each all-thread, steel rods. Apply washers and wing nuts over the all-thread, steel rods. Secure the access door by tightening the wing nuts

- ii. COVER PLATE: Cut a cover plate to the same dimensions as the third piece of access insulation (Item 6Ai) using a minimum 16 GA steel sheet. Drill holes in the cover plate that match the location of the four (4), 3/8 in. (10 mm) diameter, all-thread, steel rods and locate the holes so that the cover plate is squared to the third piece of access insulation (Item 6Ai). After all three (3) layers of access insulation (Item 6Ai) are impaled over the four (4), 3/8 in. (10 mm) diameter, all-thread, steel rods, install the cover plate. Pass the four (4), 3/8 in. diameter, all-thread, steel rods through the cover plate. Place washers and wing nuts onto each of the four (4), 3/8 in. (10 mm) diameter, all-thread, steel rods. Secure the cover plate by tightening wing nuts.

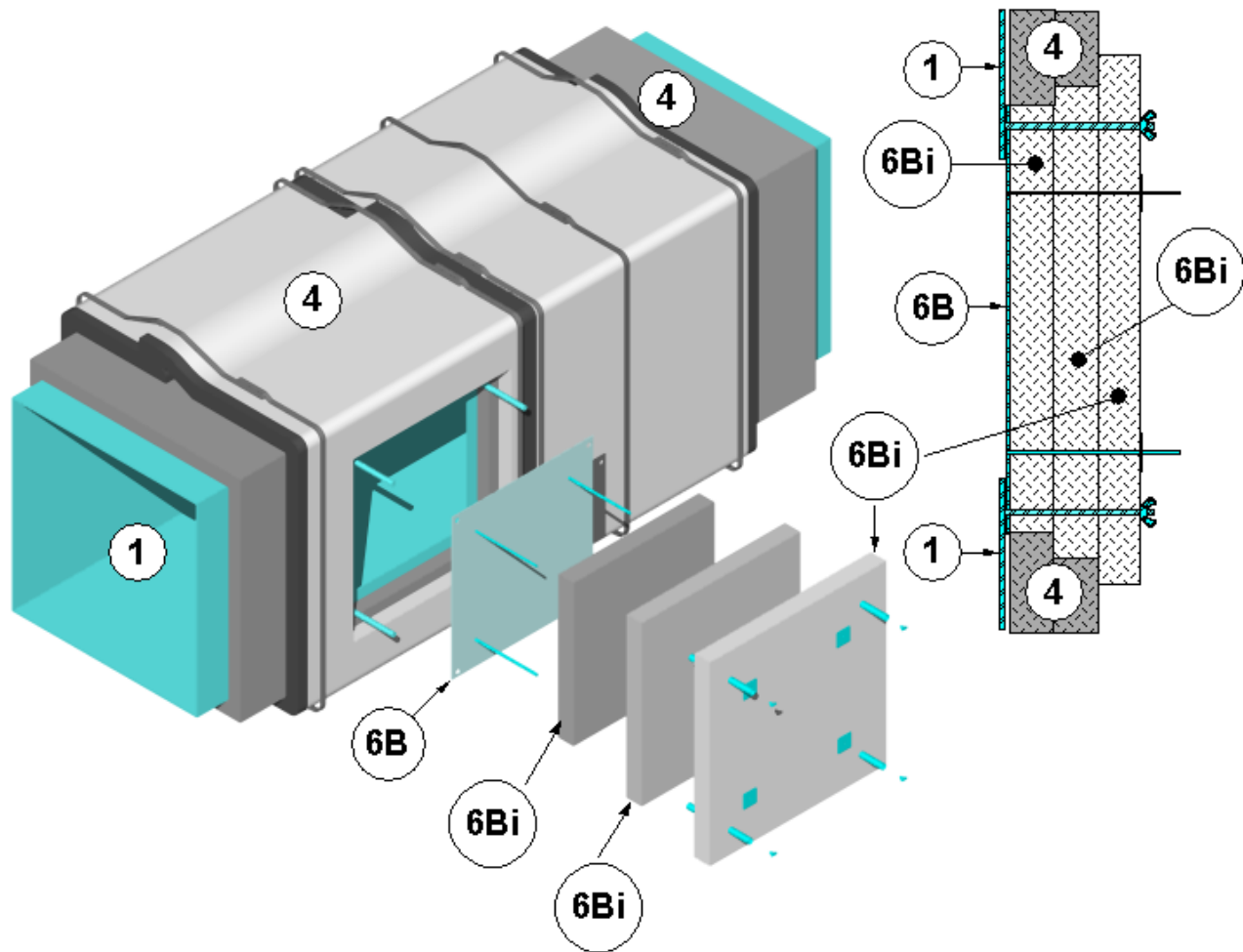

Figure 3 – Field Fabricated Access Door

B. OPTIONAL FIELD-FABRICATED ACCESS DOORS:

- Maximum Size Allowed (clear opening) 24 in. x 18 in. (610 mm x 457 mm) when installed using a pin only installation (Item 2). When installed using a banding only method (Item 3B) for insulation installation, the maximum size allowed is 10 in. x 10 in. (254 mm x 254 mm).

Refer to Figure 3. Mark a clean-out access opening location on the insulated grease duct (Item 1) at its mid-height along the horizontal section. Cut an opening in the duct insulation (Item 4) with dimensions,

each 2 in. (51 mm) greater than the dimensions of the access opening to be created in the steel wall of the grease duct (Item 1). Remove and discard the cut duct insulation (Item 4). Center and cut an opening into the side of the grease duct (Item 1) by maintaining a 1 in. (25 mm) clearance between the perimeter of the opening and the cut duct insulation (Item 4). Remove and discard the cut steel. Weld four (4), minimum 4 in. (102 mm) long, 1/4 in. (6 mm) diameter, threaded, steel rods to the grease duct (Item 1). Locate one (1) steel rod at each corner of the grease duct (Item 1) opening so that they are maximum 11 in. (279 mm) on center

and squared within the duct insulation (Item 4) opening.

Cut a, 16 GA, steel plate 1 in. (25 mm) larger than the clean-out access opening to be used as an access door. Drill clearance holes in the access door to match the all-thread, steel rod pattern. Install a nominal 1/2 in. (13 mm) wide by nominal 1/8 in. (3 mm) thick, ceramic fiber, gasket around the perimeter of the opening. Place the access door over the all-thread, steel rods. Seal the opening in the grease duct (Item 1) by overlapping the access door over the opening cut in the duct insulation (Item 4) by 1 in. (25 mm) on all sides. Weld 6-1/2 in. (165 mm) long, 12 GA, steel duct insulation pins to the access door corners at 1-1/2 in. (38 mm) from the edges of inner access door panel and additional pins as needed to maintain maximum spacing of 9 in. (229 mm) on center around the perimeter.

i. CERTIFIED Unifrax I LLC

CERTIFIED PRODUCT:
FyreWrap® Duct Insulation

MODEL: Elite™ 1.5

ACCESS INSULATION: Refer to Figure 3. Apply three (3) layers of access insulation over the field-fabricated access door (Item 6B) as follows. Cut the first piece of access insulation a minimum 1 in. (25 mm) larger than the clean-out access opening and install it over the duct insulation pins, the four (4), 3/8 in. (10 mm) diameter, threaded, steel rods, and cover the field-fabricated access door (Item 6B). Press the first piece of access insulation flush over the field-fabricated access door (Item 6B). Compress and abut the cut edges of the first piece of the access insulation against the cut edges of opening in the duct insulation (Item 4). Cut a second piece of access insulation 1 in.

(25 mm) larger on all sides than the first piece of access insulation. Square it and install it over the insulation pins and the four (4), 3/8 in. (10 mm) diameter, threaded, steel rods. Press the second piece of access insulation flush over the first piece of access insulation. Compress and abut the cut edges of the second piece of the access insulation against the cut edges of opening in the duct insulation (Item 4). Cut a third piece of rectangular access insulation a minimum of 2 in. (51 mm) larger than the second piece of access insulation on all sides, creating a “stair-step.” Seal cut edges of the third piece of access insulation with nominal 4 in. (102 mm) wide aluminum foil tape. Position, square, and impale the third piece of the access insulation over the four (4), 3/8 in. (10 mm) diameter, threaded, steel rods extending from pre-fabricated access door (Item 6B). Press the third piece of access insulation flush over second piece of access insulation. Secure access insulation to the insulation pins with 1-1/2 in. (38 mm) square or round, galvanized or stainless steel, speed clips. Turn down or cut off duct insulation pins that extend beyond the second piece of access insulation. Optional step, place maximum 4 in. (102 mm) long, steel tubing over each all-thread, steel rods. Apply washers and wing nuts over the all-thread, steel rods. Secure the access door by tightening the wing nuts.

7. SUPPORTING CONSTRUCTION: Refer to Figure 5. Use one of the following wall or floor assemblies.

A. GYPSUM WALL ASSEMBLY: Symmetrical two-hour rated gypsum wall assembly constructed of the following:

- i. Steel Studs – Minimum 25 GA galvanized steel studs measuring

- 3-5/8 in. (92 mm) wide with 1-1/4 in. (32 mm) legs spaced maximum 24 in. (610 mm) on center (O.C.). Attach studs with minimum #6 x 3/8 in. (10 mm) steel stud framing screws to floor and ceiling tracks.
- ii. Tracks – Channel U-shaped floor and ceiling runners measuring 1/2 in. (13 mm) deep by 3-5/8 in. (92 mm) wide, which are secured to floor and ceiling with 1 in. (25 mm) long fasteners suitable for the mounting to substrate and spaced maximum 18 in. (457 mm) O.C.
 - iii. Gypsum Board – Cover studs and runners with two layers of 5/8 in. (16 mm) thick, Type X gypsum board on each face. Fasten base layer of gypsum board to steel studs with #6, 1-1/8 in. (29 mm) long bugle head phillips drywall screws spaced maximum 12 in. (305 mm) O.C. Fasten face layer of gypsum board with #6, 1-5/8 in. (41 mm) long bugle phillips drywall screws spaced maximum 8 in. (203 mm) O.C. Apply vinyl or casein, dry or premixed joint compound to face layers of gypsum board in two coats to all exposed screw heads and gypsum board joints. Embed minimum 2 in. (51 mm) wide paper, plastic or fiberglass tape in first layer of joint compound over joints in gypsum board. Minimum wall assembly thickness is 6 in. (152 mm) measured from face layer of gypsum board to opposite face layer of gypsum board.

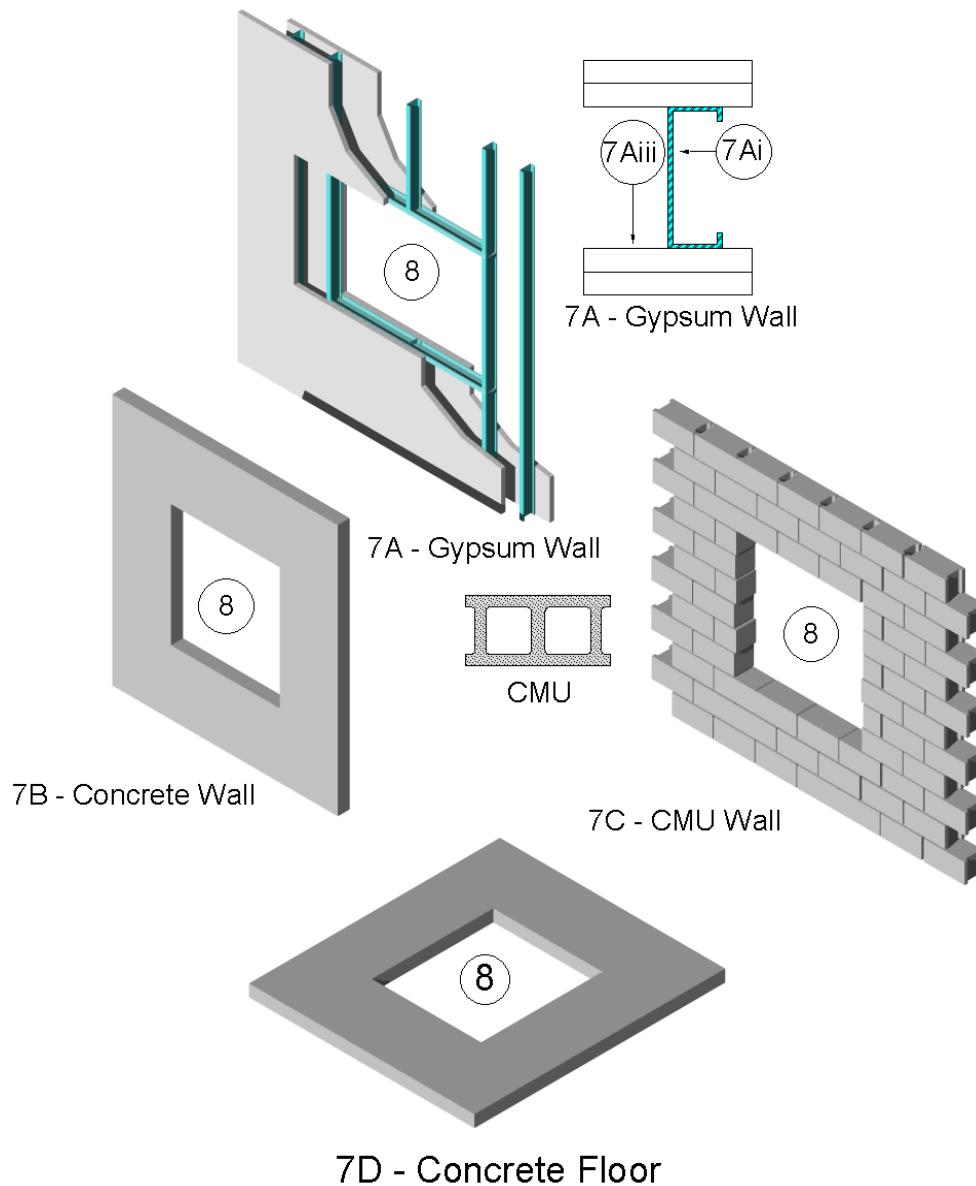

Figure 5 – Supporting Constructions

B. CONCRETE WALL ASSEMBLY: Use a symmetrical, two-hour rated, solid concrete, wall assembly made from reinforced lightweight or normal weight (100-150 pcf density or 1600-2400 kg/m³ density) concrete

constructed of solid concrete with a minimum concrete thickness measured from exposed face to exposed face using one of the following:

- i. lightweight concrete is 4.6 in. (117 mm);
 - ii. sand-lightweight concrete is 4.6 in. (117 mm);
 - iii. carbonate aggregate concrete is 4.6 in. (117 mm); and
 - iv. siliceous aggregate concrete is 5.0 in. (127 mm).
- C. MASONRY WALL ASSEMBLY: Use a symmetrical, two-hour rated, nominal 8 in. x 8 in. x 16 in. (203 mm x 203 mm x 406 mm) CMU, wall assembly made from lightweight or normal weight (100-150 pcf density or 1600-2400 kg/m³ density) concrete.
- D. CONCRETE FLOOR ASSEMBLY: Symmetrical two-hour rated solid concrete floor assembly made from reinforced lightweight or normal weight (100-150 pcf density or 1600-2400 kg/m³ density) concrete constructed of solid concrete with a minimum concrete thickness measured from exposed face to exposed face using one of the following:
- i. lightweight concrete is 4.6 in. (117 mm);
 - ii. sand-lightweight concrete is 4.6 in. (117 mm);
 - iii. carbonate aggregate concrete is 4.6 in. (117 mm); and
 - iv. siliceous aggregate concrete is 5.0 in. 127 mm)
8. OPENING – Create a rectangular opening in the supporting construction (Item 7) with each side measuring no more than 4 in. (102 mm) greater than the corresponding dimension of the penetrating item. The penetrating item dimensions are considered as the bare grease duct (Item 1) dimensions plus 3 in. (76 mm) for each layer of duct insulation (Item 4) passing through the supporting

construction. See Figures 6 and 7 for various insulation installation options at the penetration. Maintain a clearance of minimum 1 in. (25 mm) to maximum 3 in. (76 mm) to the penetrating item. Measure this as the distance to the bare grease duct (Item 1) wall minus 1-1/2 in. for each layer of duct insulation (Item 4) passing through the supporting construction (Item 7). Position the grease duct (Item 1) concentrically or eccentrically in the opening, maintaining the minimum and maximum clearance requirements.

9. PENETRATION FIRESTOP: Install firestop between the supporting construction (Item 7) and the insulated or un-insulated grease duct (Item 1). Use a firestop system constructed of the following components.

A. CERTIFIED COMPANY:
Unifrax I LLC

CERTIFIED PRODUCT:
Duct Insulation

MODEL: FyreWrap® Elite™ 1.5

PACKING MATERIAL: Fill the entire annular space's width with certified duct insulation without the encapsulation (foil scrim).

For Options 2 through 8 in Figures 6 and 7, cut the packing material into strips not less than one and one half (1-1/2) times the nominal width of the annular space. Compress packing material 33% and insert it into the annular space, filling the entire depth at the specified compression.

For Option 1 in Figures 6 and 7, increase the compression to 50%, with the packing material strips cut to not less than two times the nominal width of the annular space, filling the entire depth at the specified compression.

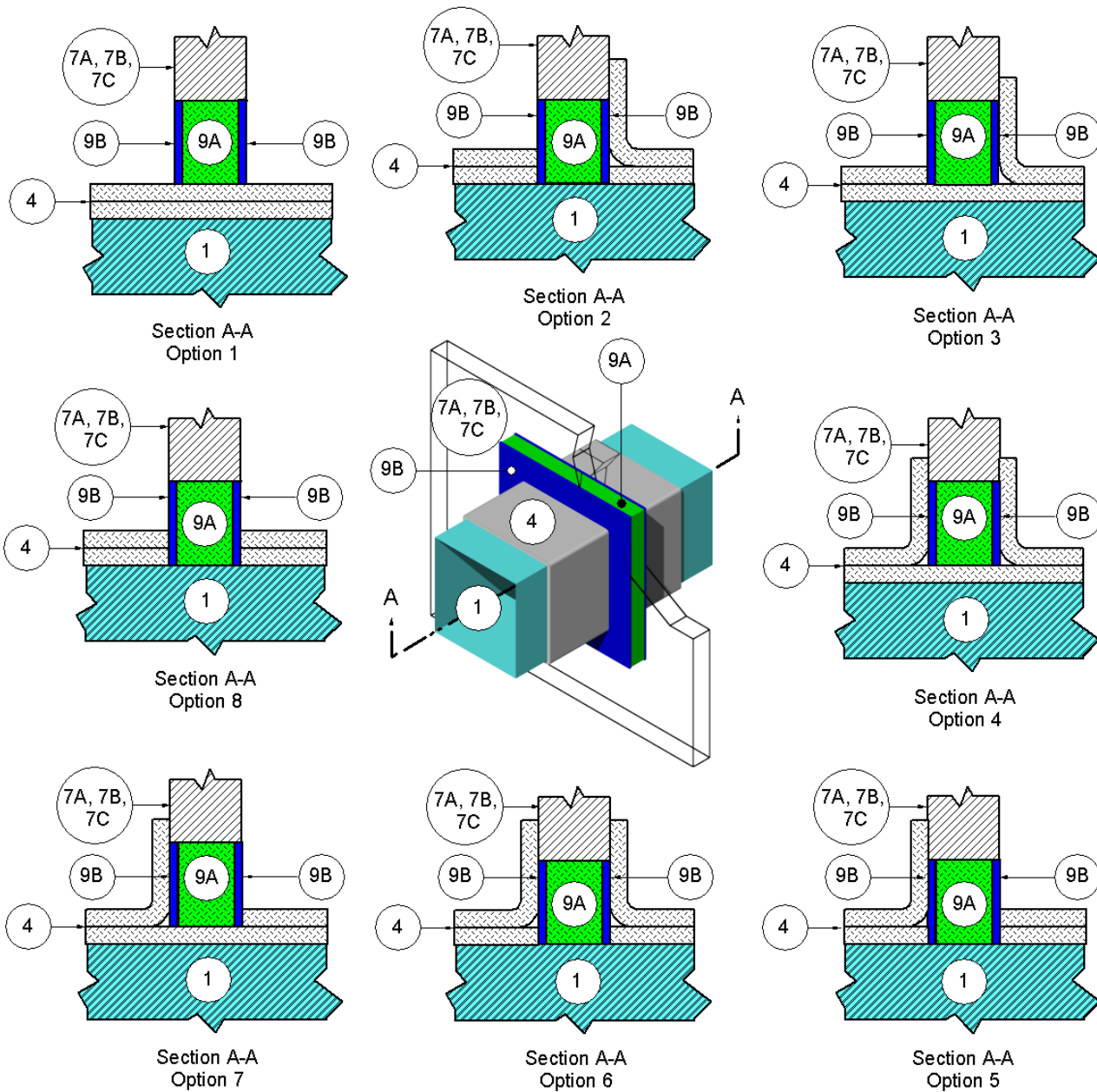

Figure 6 – Penetration Firestops for Wall Supporting Constructions

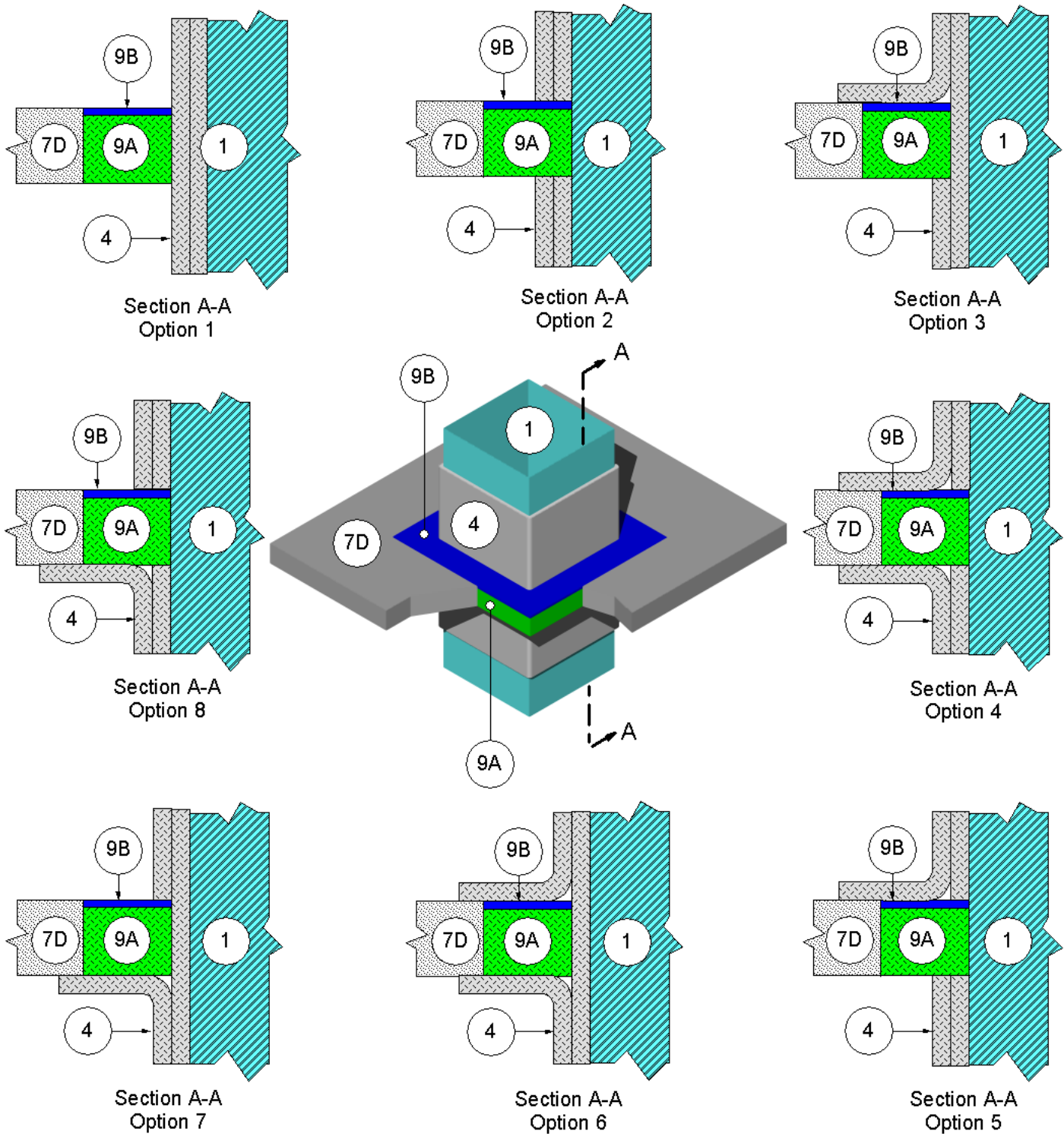

Figure 7 – Penetration Firestops for Floor Supporting Construction

For wall assemblies in Figure 6, recess the surface of packing material nominally 1/4 in. (6 mm) from surfaces of both faces of the supporting construction (Item 7).

For floor assembly in Figure 7, recess the surface of packing material nominally 1/4 inch (6 mm) from the top surface of the supporting construction (Item 7).

B. CERTIFIED COMPANY:

3M Company

CERTIFIED PRODUCT: Sealant
MODEL: 3M™ Fire Barrier™
Water-Tight 1000-NS Silicone

CERTIFIED COMPANY:

Tremco Incorporated

CERTIFIED PRODUCT: Sealant
MODEL: TREMstop Silicone Fyre-
Sil® GG

LISTED COMPANY:

Specified Technologies
Incorporated (STI)

LISTED PRODUCT: Sealant

MODEL: SpecSeal® Series SSS

LISTED COMPANY: HILTI

LISTED PRODUCT: Sealant

MODEL: FS-ONE

FILL, VOID OR CAVITY
MATERIAL:

Use the sealant listed above. For wall assemblies or floor assemblies, install minimum 1/4 in. (6 mm), of fill, void, or cavity material into the recess over the entire surface of the packing material (Item 9A). Screed the fill, void, or cavity material flush with the surface of the supporting construction (Item 7). Overlap a minimum of 1/2 in. (13 mm), the fill, void or cavity material onto face of grease duct (Item 1) or duct insulation (Item 4) and supporting construction (Item 7).