

**Unifrax I LLC**  
**Design No. UNI/BI 120-15**  
**FIRE RESISTANT GREASE DUCT**  
**FyreWrap® Elite® 1.5 Duct Insulation**  
 CAN/ULC S144  
 Fire Resistance Rating – 2 Hour  
 Fire Inside Duct – Meets Requirements  
 Fire Outside Duct (Fire Engulfment):  
 Stability – 2 Hour  
 Integrity – 2 Hour  
 Insulation – 2 Hour  
 CAN/ULC S115  
 FTH Rating – 2 Hour

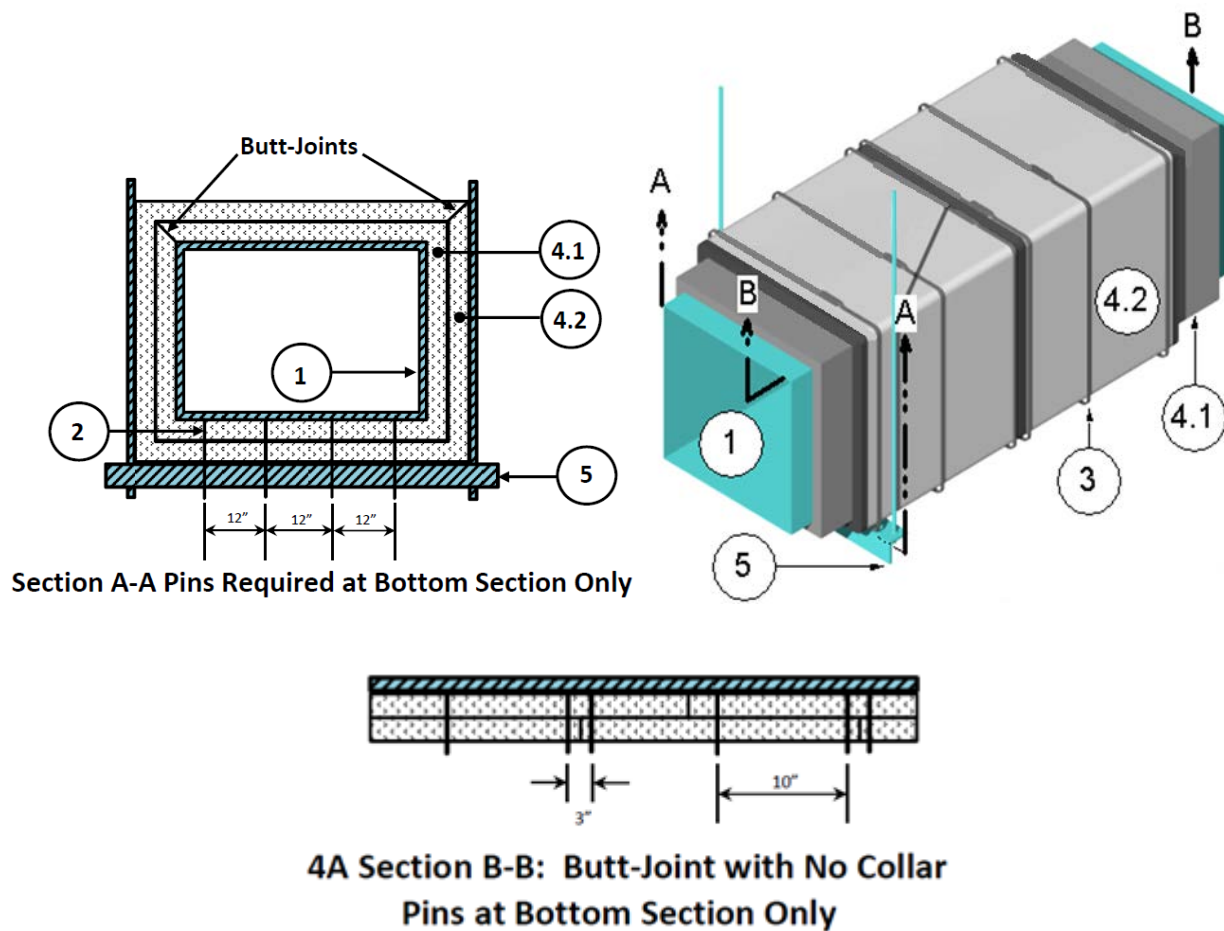

Figure 1

1. **GREASE DUCT:** Use a continuously-welded, liquid-tight, rectangular duct system with horizontal and vertical shafts constructed of 16 GA sheet steel with a max. 1152 in<sup>2</sup> area and a max. 48 in. dimension. When required, equip the duct with an access door (Item 6).
  - A. Reinforce the grease duct to NFPA 96 requirements designed to carry the weight of the grease duct assembly covered with two layers of duct insulation (Item 4) under a fire load equivalent to that of the ISO 6944 exposure and the ISO 834 time-temperature curve for the rated period.
  - B. Rigidly support the grease duct as specified in Item 5 or in accordance with IMC requirements when not specified herein or when those requirements are greater.
2. **PINS:** (Not required when grease duct (Item 1) width and height are both less than or equal to 24 in.) Refer to Figure 1. Use min. 12 GA, 5 in. long, steel insulation pins or min. 12 GA, steel cup head insulation pins. Weld pins to the grease duct (Item 1) before application of first layer of duct insulation (Item 4).
  - A. **BUTT JOINT (No Collar)** – Refer to Figure 1, 4A Section B-B. Locate pins on the bottom side of the grease duct (Item 1), and meet the following requirements:
    - i. Space pins max. 12 in. apart in rows parallel to the longitudinal axis of the grease duct (Item 1). Locate pins max. 6 in. from sides or edges of the grease duct (Item 1). Refer to Figure 1, Section A-A.
    - ii. Space pins 3 in. apart centered directly over each outer layer transverse joint, and a max. 10 in. apart elsewhere along the length of the grease duct (Item 1). Refer to Figure 1, 4A Section B-B.
    - iii. After the second layer of duct insulation (Item 4) is installed, place min. 2-1/2 x 2-1/2 in. square, galvanized steel, self-locking washer clips onto each duct insulation pin.
    - iv. After all the clips are installed, cut off or bend flush with duct insulation (Item 4) the pins that are too long.
3. **BANDING:** Min. 1/2 in. wide, 0.015 in. thick stainless steel bands or min. 1/2 in. wide, 0.015 in. thick carbon steel bands and secured with min. 1 in. long stainless or carbon steel crimp clamps to be used with corresponding banding type. When needed to ease installation, use filament tape as a temporary hold for the duct insulation (Item 4) prior to banding. After second layer of duct insulation (Item 4) is installed, place banding a max. 1-1/2 in. from all duct insulation edges (Item 4) and a max. of 10-1/2 in. on center (oc) elsewhere. Tension the banding to hold the duct insulation (Item 4) in place without cutting or damaging the duct insulation (Item 4) or grease duct (Item 1).
4. **CERTIFIED COMPANY:** Unifrax I LLC  
**CERTIFIED PRODUCT:** Duct Insulation  
**MODEL:** FyreWrap® Elite® 1.5  
**DUCT INSULATION:** Apply two layers of the nominal 1-1/2 in. thick, 6 pcf density duct insulation over the entire surface of the grease duct (Item 1). Apply both layers of duct insulation with transverse and longitudinal joints butted to form a 1 in. compressed butt joint (created using an initial 1 in. overlap). Locate inner layer longitudinal joints (Figure 1, 4.1) at a corner of the grease duct (Item 1). Offset the outer layer joint (Figure 1, 4.2) to a different corner. Use blanket, available in various widths, that is fully encapsulated with a polypropylene-foil scrim. Cover all visually-exposed ends and edges of duct insulation with nominal 3 in. wide aluminum foil tape.

5. **SUPPORTS:** Support the horizontal portion of the insulated grease duct (Item 1) using an un-insulated "trapeze" system composed of a steel angle as the trapeze cross-member and two all-thread, steel rods connected using nuts and washers. Connect the all-thread steel rods to the bottom of the floor assembly using an attachment method designed to carry the weight of the grease duct (Item 1) with duct insulation (Item 4) under a fire load equivalent to that of the ISO 6944 exposure and the ISO 834 time-temperature curve for the rated period. Place one all-thread steel rod at each end of the trapeze cross-member. Center grease duct (Item 1) with duct insulation (Item 4) on trapeze cross-member. Space all-thread steel rods a min. of 1 in. and max. 6 in. from surface of the insulated grease duct. Extend trapeze cross-member at least 2 in. past each all-thread, steel rod. Use min. 1-1/2 x 1-1/2 x 1/8 in. steel angle with min. 3/8 in. diameter all-thread steel rods, when trapeze supports spaced a max. 60 in. oc. Use min. 2 x 2 x 1/4 in. steel angle with min. 1/2 in. diameter all-thread steel rods, when trapeze supports spaced a max. 72 in. oc. Where grease duct (Item 1) penetrates a fire rated floor ceiling assembly (Item 7D), support, prior to installing duct insulation (Item 4), using un-insulated 1-1/2 x 1-1/2 x 1/4 in. steel angles welded to the grease duct (Item 1) and a supporting steel frame designed and constructed to meet the requirements of the International Mechanical Code.

6. **ACCESS DOOR:** When required by NFPA 96, install an access door using one of the options described below:

A. LISTED COMPANY – Ductmate Industries Incorporated

LISTED PRODUCT – Pre-Fabricated Access Door

MODELS:

- Ductmate™ Ultimate™ (Max. Size Allowed 24 in. x 18 in.)
- Ductmate™ FD 2000 (F2-HT) (Max. Size Allowed 12 in. x 8 in.)

LISTED COMPANY – CL Ward, Inc.

LISTED PRODUCT – Pre-Fabricated Access Door

MODELS:

- High Temp #HT2000 (Max. Size Allowed 12 in. x 8 in.)

LISTED COMPANY – Price Manufacturing Corp

LISTED PRODUCT – Pre-Fabricated Access Door

MODELS:

- FD2000 Fire Door (Max. Size Allowed w/o Field Modifications 12 in. x 8 in.) \*(Max. Size Allowed w/ Field Modifications 24 in. x 18 in.)

OPTIONAL PRE-FABRICATED ACCESS DOORS – Refer to Figure 2.

Mark a clean-out access opening location on the insulated grease duct (Item 1) at its mid-height along the horizontal section. Cut an opening in the duct insulation (Item 4) the same size as the outside dimension of the desired pre-fabricated access door model. Remove and discard the cut duct insulation (Item 4). Cut an opening into the side of the grease duct (Item 1) according to the manufacturer's instructions for the size of the pre-fabricated access door to be installed. Install and tightly secure the pre-fabricated access door in accordance with the manufacturer's instructions to the grease duct (Item 1). Cut the outer layer of duct insulation (Item 4) so that a 1 in. perimeter of the inner layer of duct insulation (Item 4) is seen, creating a "stair-step".

\*For Price doors larger than 12 in. x 8 in., modifications need to be made in the field. For sizes up to and including 18 in. x 14 in., four 3/8 in. threaded steel rods (one in each corner of the access door) will need to be added to secure the access door and the cover plate. They should be located 2 in. from the edges of the

access door. For sizes larger than 18 in. x 14 in. up to the max. size of 24 in. x 18 in., two bolts will need to be added 8-1/2 in. apart. These shall be centrally located on the door, on either side of the handle, and aligned with the longer dimension of the door.

All additional bolts are to be welded to the inner plate of the access door and secured to the cover plate with wing nuts. Drill holes in the outer plate of the access door and the cover plate to match bolt locations.

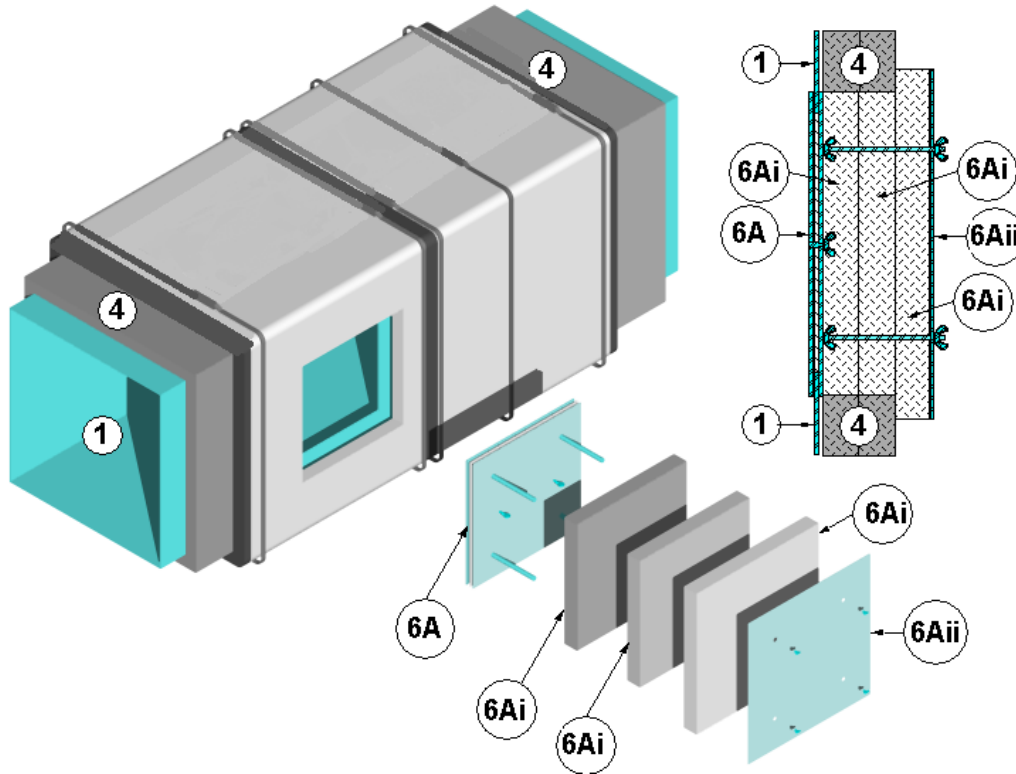

Figure 2 – Ductmate Pre-fabricated Access Door

i. CERTIFIED COMPANY – Unifrax I LLC

CERTIFIED PRODUCT – Duct Insulation

MODEL – FyreWrap® Elite™ 1.5

ACCESS INSULATION – Refer to Figure 2. Remove the four 3/8 in. diameter corner-thumb bolts and replace them with four 3/8 in. diameter all-thread steel rods extending from pre-fabricated access door (Item 6A). Apply three layers of access insulation over the pre-fabricated access door (Item 6A) as follows. Cut the first piece of rectangular access insulation a min.

1 in. larger on all sides than the clean-out access opening. Position, square, and impale the first piece of the access insulation over the four 3/8 in. diameter all-thread steel rods extending from pre-fabricated access door (Item 6A). Press the first piece of access insulation flush over the pre-fabricated access door (Item 6A). Compress and abut the cut edges of the first piece of the access insulation against the cut edges of opening in the duct insulation (Item 4). Cut a second piece of access insulation 1 in. larger on all sides than the first piece of access insulation. Press the

second piece of access insulation flush over the first piece of access insulation. Compress and abut the cut edges of the second piece of the access insulation against the cut edges of opening in the duct insulation (Item 4). Cut a third piece of rectangular access insulation a min. of 2 in. larger than the second piece of access insulation on all sides, creating a stair-step". Seal cut edges of the third piece of access insulation with nominal 3 in. wide aluminum foil tape. Position, square, and impale the third piece of the access insulation over the four 3/8 in. diameter all-thread steel rods extending from pre-fabricated access door (Item 6A). Press the third piece of access insulation flush over second piece of access insulation. Secure access insulation to the insulation pins with 1-1/2 in. square or round, galvanized or stainless steel, speed clips. Turn down or cut off insulation pins that extend beyond the second piece of access insulation. Optional step;

place max. 4 in. long steel tubing over each all-thread steel rod. Apply washers and wing nuts over the all-thread steel rods. Secure the access door by tightening the wing nuts.

- ii. COVER PLATE – Cut a cover plate to the same dimensions as the third piece of access insulation (Item 6Ai) using a minimum 16 GA steel sheet. Drill holes in the cover plate that match the location of the four (4), 3/8 in. diameter, all-thread, steel rods and locate the holes so that the cover plate is squared to the third piece of access insulation (Item 6Ai). After all three (3) layers of access insulation (Item 6Ai) are impaled over the four (4), 3/8 in. diameter, all-thread, steel rods, install the cover plate. Pass the four (4), 3/8 in. diameter, all-thread, steel rods through the cover plate. Place washers and wing nuts onto each of the four (4), 3/8 in. diameter, all-thread, steel rods. Secure the cover plate by tightening wing nuts.

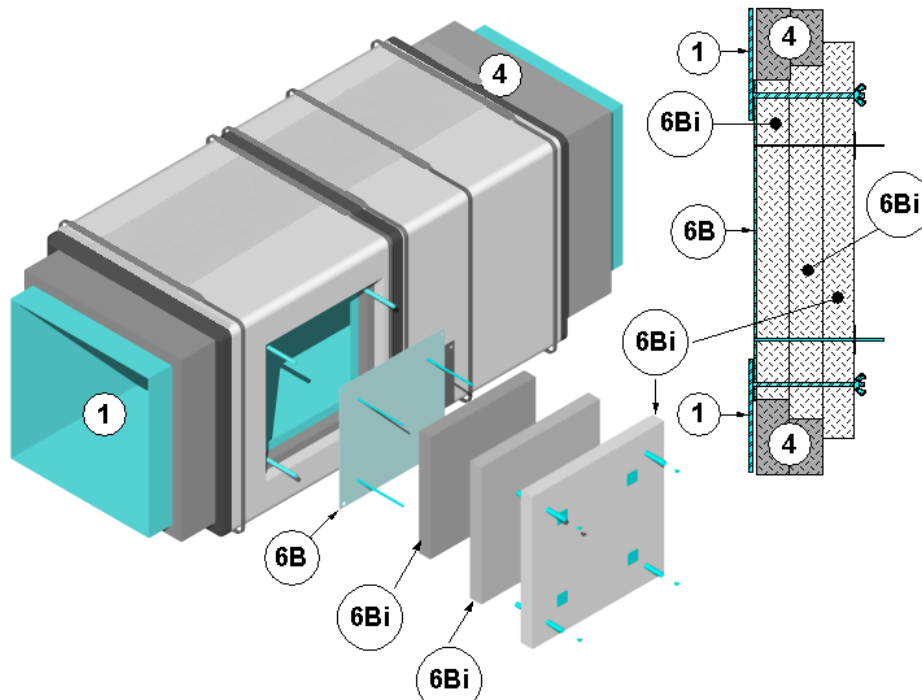

Figure 3 – Field Fabricated Access Door



- B. OPTIONAL FIELD-FABRICATED ACCESS DOORS – Refer to Figure 3. Mark a clean-out access opening location on the insulated grease duct (Item 1) at its mid-height along the horizontal section. Cut a 26 in. x 20 in. opening in the duct insulation (Item 4). Remove and discard the cut duct insulation (Item 4). Cut and center a 24 in. x 18 in. opening into the side of the grease duct (Item 1) by maintaining a 1 in. clearance between the perimeter of the opening and the cut duct insulation (Item 4). Remove and discard the cut steel. Weld four min. 4 in. long, 1/4 in. diameter, all-thread steel rods to the grease duct (Item 1). Locate one steel rod at each corner of the grease duct (Item 1) opening so that they are 11 in. oc and squared within the duct insulation (Item 4) opening.

Cut a 26 in. x 20 in., 16 GA, steel plate to be used as an access door. Drill clearance holes in the access door to match the all-thread steel rod pattern. Install a nominal 1/2 in. wide by nominal 1/8 in. thick, ceramic fiber gasket around the perimeter of the opening. Place the access door over the all-thread steel rods. Seal the opening in the grease duct (Item 1) by overlapping the access door over the opening cut in the duct insulation (Item 4) by 1 in. on all sides. Weld four min. 6-1/2 in. long, 12 GA, steel duct insulation pins to the access door corners so that the pins are 9 in. on center.

- i. CERTIFIED COMPANY – Unifrax I LLC

CERTIFIED PRODUCT – FyreWrap® Duct Insulation

MODEL – Elite™ 1.5

ACCESS INSULATION – Refer to Figure 3. Apply three layers of access insulation over the field-fabricated access door (Item 6B) as follows. Cut the first piece of access insulation a min. 1 in. larger than the

clean-out access opening and install it over the duct insulation pins, the four 3/8 in. diameter, all-thread steel rods, and cover the field-fabricated access door (Item 6B). Press the first piece of access insulation flush over the field-fabricated access door (Item 6B). Compress and abut the cut edges of the first piece of the access insulation against the cut edges of opening in the duct insulation (Item 4). Cut a second piece of access insulation 1 in. larger on all sides than the first piece of access insulation. Square it and install it over the insulation pins and the four 3/8 in. diameter, all-thread steel rods. Press the second piece of access insulation flush over the first piece of access insulation. Compress and abut the cut edges of the second piece of the access insulation against the cut edges of opening in the duct insulation (Item 4). Cut a third piece of rectangular access insulation a min. of 2 in. larger than the second piece of access insulation on all sides, creating a "stair-step". Seal cut edges of the third piece of access insulation with nominal 3 in. wide aluminum foil tape. Position, square, and impale the third piece of the access insulation over the four 3/8 in. diameter, all-thread steel rods extending from pre-fabricated access door (Item 6B). Press the third piece of access insulation flush over second piece of access insulation. Secure access insulation to the insulation pins with 1-1/2 in. square or round, galvanized or stainless steel, speed clips. Turn down or cut off duct insulation pins that extend beyond the second piece of access insulation. Optional step; place max. 4 in. long steel tubing over each all-thread steel rod. Apply washers and wing nuts over the all-thread steel rods. Secure the access door by tightening the wing nuts.

7. **SUPPORTING CONSTRUCTION:** Refer to Figure 5. Use one of the following wall or floor assemblies.

A. **GYPSUM WALL ASSEMBLY** – Symmetrical two-hour rated gypsum wall assembly constructed of the following:

- i. **Steel Studs** – Min. 25 GA galvanized steel studs measuring 3-5/8 in. wide with 1-1/4 in. legs spaced max. 24 in. oc. Attach studs with min. #6 x 3/8 in. steel stud framing screws to floor and ceiling tracks.
- ii. **Tracks** – Channel U-shaped floor and ceiling runners measuring 1/2 in. deep x 3-5/8 in. wide, which are secured to floor and ceiling with 1 in. long fasteners suitable for the mounting to substrate and spaced max. 18 in. oc.

- iii. **Gypsum Board** – Cover studs and runners with two layers of 5/8 in. thick, Type X gypsum board on each face. Fasten base layer of gypsum board to steel studs with #6, 1-1/8 in. bugle-head Phillips drywall screws spaced max. 12 in. oc. Fasten face layer of gypsum board with #6, 1-5/8 in. long bugle-head Phillips drywall screws spaced max. 8 in. oc. Apply vinyl or casein, dry or premixed, joint compound to face layers of gypsum board in two coats to all exposed screw heads and gypsum board joints. Embed min. 2 in. wide paper, plastic, or fiberglass tape in first layer of joint compound over joints in gypsum board. Min. wall assembly thickness is 6 in. measured from face layer of gypsum board to opposite face layer of gypsum board.

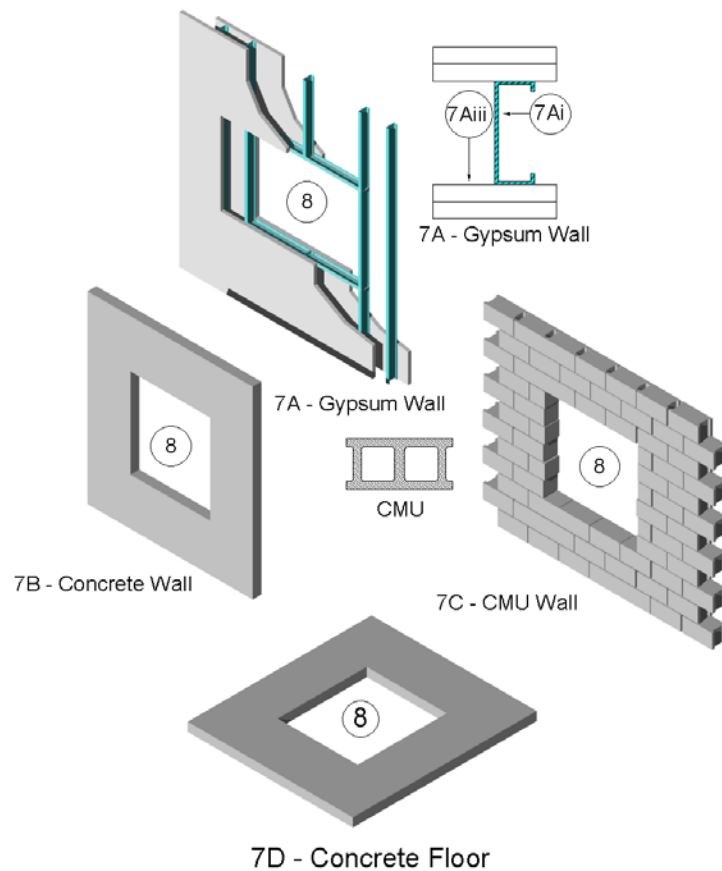

Figure 5 – Supporting Constructions

B. CONCRETE WALL ASSEMBLY – Use a symmetrical two-hour rated, solid concrete wall assembly, made from reinforced lightweight or normal weight (100-150-pcf density or 1600-2400 kg/m<sup>3</sup> density) concrete constructed of solid concrete with a min. concrete thickness measured from exposed face to exposed face using one of the following:

- i. lightweight concrete is 4.6 in.;
- ii. sand-lightweight concrete is 4.6 in.;
- iii. carbonate aggregate concrete is 4.6 in.; and
- iv. Siliceous aggregate concrete is 5 in.

C. MASONRY WALL ASSEMBLY – Use a symmetrical two-hour rated, nominal 8 x 8 x 16 CMU wall assembly, made from lightweight or normal weight (100-150 pcf density or 1600-2400 kg/m<sup>3</sup> density) concrete.

D. CONCRETE FLOOR ASSEMBLY – Symmetrical two-hour rated solid concrete floor assembly, made from reinforced lightweight or normal weight (100-150 pcf density or 1600-2400 kg/m<sup>3</sup> density) concrete constructed of solid concrete with a min. concrete thickness measured from exposed face to exposed face using one of the following:

- i. lightweight concrete is 4.6 in.;
- ii. sand-lightweight concrete is 4.6 in.;
- iii. carbonate aggregate concrete is 4.6 in.; and
- iv. Siliceous aggregate concrete is 5 in.

8. **OPENING:** Create an opening in the supporting construction (Item 7). Position the grease duct (Item 1)

concentrically or eccentrically in the opening so that the annular space ranges from min. 1/2 in. to max. 4-1/2 in. Establish an opening designed to house the grease duct (Item 1) with or without duct insulation (Item 4) and the desired annular space but not exceeding a cross-sectional area of max. 3192.25 in<sup>2</sup> and a max. dimension of 56-1/2 in.

9. **PENETRATION FIRESTOP:** Install two-hour fire-resistant, ASTM E 814 compliant, firestop system. Install firestop between the supporting construction (Item 7) and the insulated or un-insulated grease duct (Item 1). Use a firestop system constructed of the following components.

A. CERTIFIED COMPANY – Unifrax I LLC

CERTIFIED PRODUCT – Duct Insulation

MODEL – FyreWrap® Elite™ 1.5

PACKING MATERIAL – Fill the entire annular space width with certified duct insulation without the encapsulation (foil scrim) or an Intertek certified, min. 4 pcf density, mineral wool meeting the following requirements.

Option 1 – Cut the packing material into strips not less than two times the width of the annular space to be filled. Compress packing material nominally 50% and insert packing material into the annular space.

Options 2 thru 8 – Cut the packing material into strips not less than one and one half times the width of the annular space to be filled. Compress packing material nominally 33% and insert packing material into the annular space.



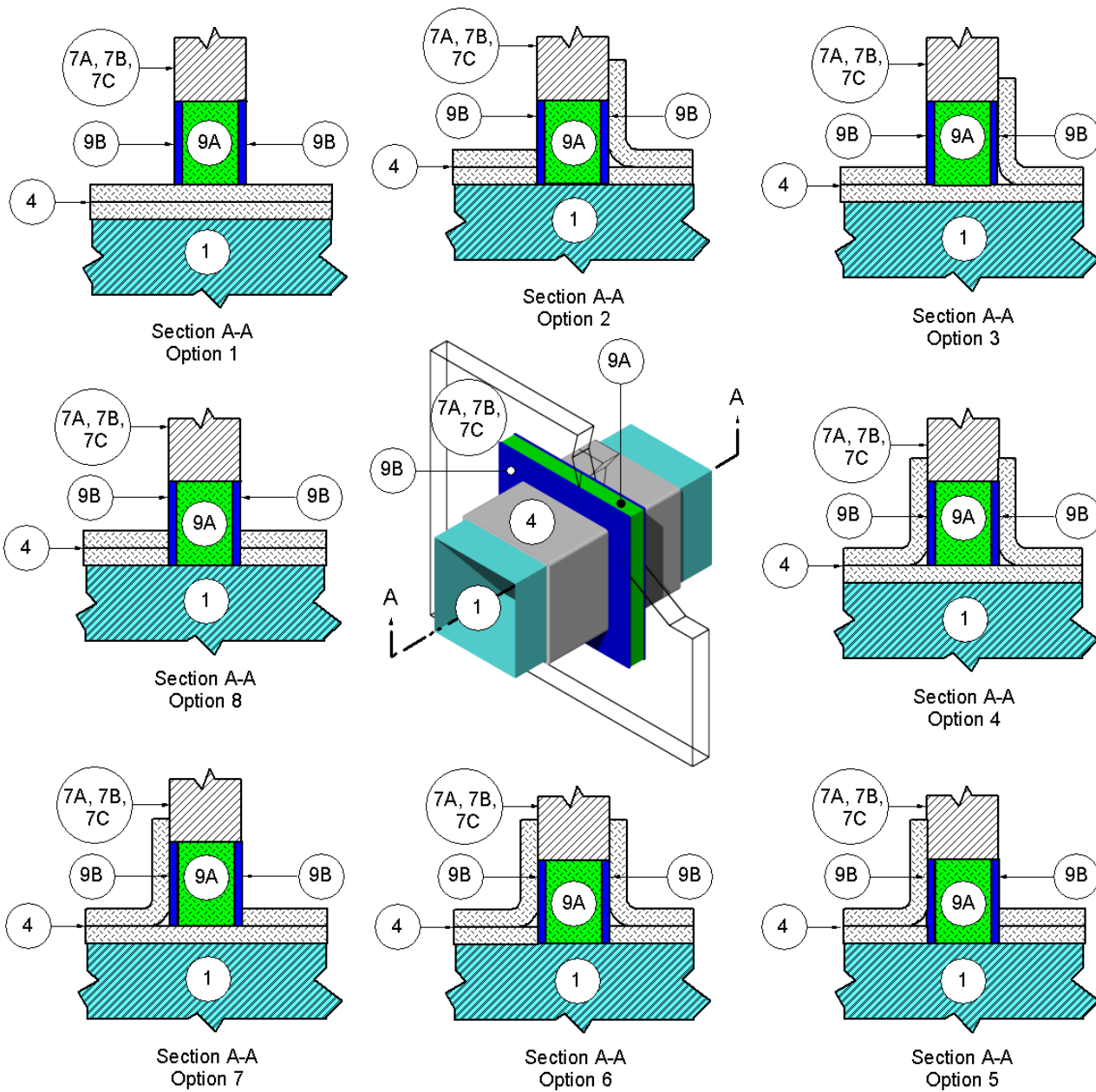

Figure 6 – Penetration Firestops for Wall Supporting Constructions

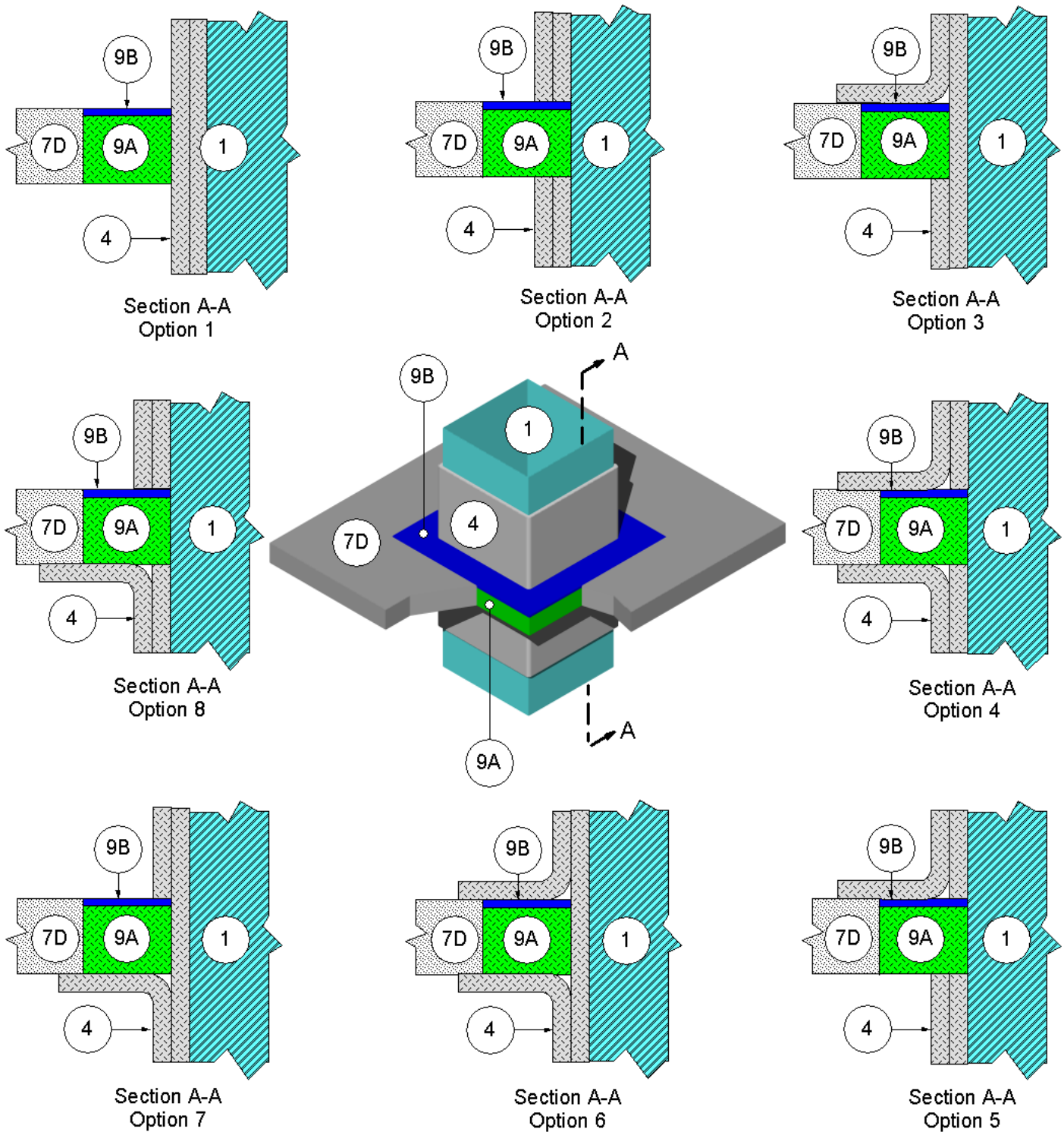

Figure 7 – Penetration Firestops for Floor Supporting Construction

For wall assemblies in Figure 6, recess the surface of packing material nominally 5/8 in. from surfaces of both faces of the supporting construction (Item 7).

For floor assembly in Figure 7, recess the surface of packing material nominally 3/8 in. from the top surface of the supporting construction (Item 7) and install a min. depth of 4-1/2 in.

**B. CERTIFIED COMPANY – 3M Company**

**CERTIFIED PRODUCT – Sealant**

**MODEL – 3M™ Fire Barrier™ Water-Tight 1000-NS Silicone, 1000-SL Silicone (Floor Assembly Only), 2000+ Silicone, or CP 25 WB+**

**CERTIFIED COMPANY – Tremco Incorporated**

**CERTIFIED PRODUCT – Sealant**

**MODEL – TREMstop Silicone Fyre-Sil® GG and Fyre-Sil® SL (Floor Assembly Only)**

**LISTED COMPANY – Specified Technologies Incorporated (STI)**

**LISTED PRODUCT – Sealant**

**MODEL – SpecSeal® Series SSS**

**LISTED COMPANY – HILTI**

**LISTED PRODUCT – Sealant**

**MODEL – FS-ONE**

**FILL, VOID OR CAVITY MATERIAL –** Use one of the sealants listed above. For wall assemblies or floor assemblies, install min. 5/8 in. or 3/8 in. respectively, of fill, void, or cavity material into the recess over the entire surface of the packing material (Item 9A). Screed the fill, void, or cavity material flush with the surface of the supporting construction (Item 7). Overlap a min. of 1/2 in., the fill, void, or cavity material onto face of grease duct (Item 1) or duct insulation (Item 4) and supporting construction (Item 7).